

SST & SSTIII DIMENSIONS



A ROMAC ORIGINAL

1980 - Stainless Steel Tapping Sleeve

Corrosion resistant, provides full circumferential seal.

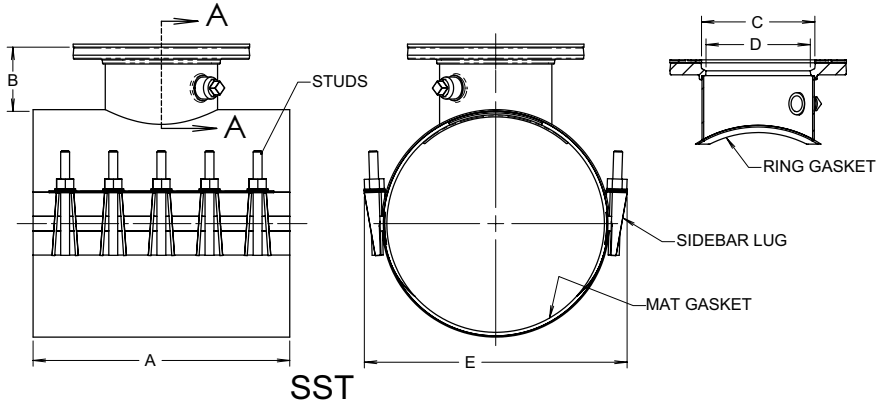

SST

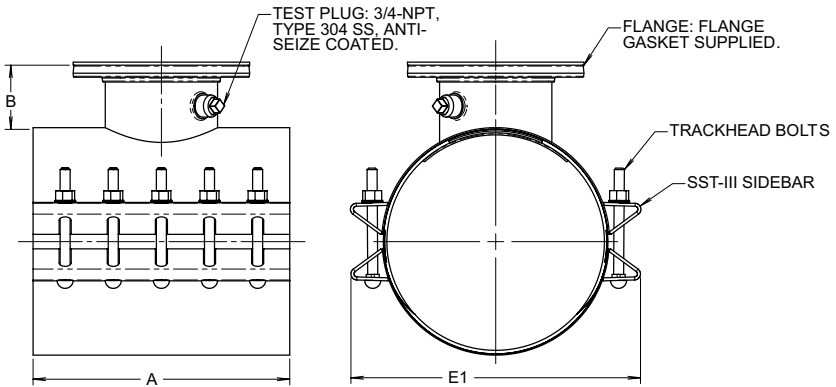

SSTIII

| DIMENSIONS | | | | | | | | |
|-------------|----------------------------|------------|------|------|-------|--------|---------------|---------------|
| FLANGE SIZE | CATALOG NUMBER | # OF BOLTS | A | B | C | D | E | E1 |
| 3" | 4.60 - 5.30 | 8 | 12.0 | 4.00 | 4.03 | 3 1/2 | PIPE OD + 3.0 | PIPE OD + 4.6 |
| | 5.60 - 19.30 | 10 | 16.0 | | | | | |
| | 19.70 - 26.50 | 14 | 20.0 | | | | | |
| | 27.80 - 32.00 ¹ | 21 | 20.0 | | | | | |
| 4" | 4.60 - 5.30 | 8 | 12.0 | 4.00 | 5.03 | 4 1/2 | PIPE OD + 3.0 | PIPE OD + 4.6 |
| | 5.60 - 19.30 | 10 | 16.0 | | | | | |
| | 19.70 - 26.50 | 14 | 20.0 | | | | | |
| 6" | 6.25 - 17.95 | 10 | 16.0 | 4.5 | 7.03 | 6 1/2 | PIPE OD + 3.0 | PIPE OD + 4.6 |
| | 18.25 - 26.50 | 14 | 20.0 | | | | | |
| | 27.80 - 32.00 ¹ | 21 | 20.0 | | | | | |
| 8" | 8.30 - 26.50 | 14 | 20.0 | 5 | 9.03 | 8 1/2 | PIPE OD + 3.0 | PIPE OD + 4.6 |
| | 27.80 - 32.00 ¹ | 21 | 20.0 | | | | | |
| 10" | 10.73 - 26.50 | 16 | 24.0 | 5.5 | 11.03 | 10 1/2 | PIPE OD + 3.0 | PIPE OD + 4.6 |
| | 27.80 - 32.00 ¹ | 24 | 24.0 | | | | | |
| 12" | 12.75 - 16.78 | 20 | 30.0 | 5.75 | 13.03 | 12 1/2 | PIPE OD + 3.0 | PIPE OD + 4.6 |
| | 17.55 - 26.50 | 20 | 30.0 | | | | | |
| | 27.80 - 32.00 ¹ | 30 | 30.0 | | | | | |

¹ SSTIII Only

- 6.25 & 6.60 sizes not available with 6" branch.
- 8.30 size not available with 8" branch.

- 10.73 size not available with 10" branch
- 12.75 - 12.90 sizes: 1/2" undersize cutter recommended.



SST-MJ & SSTIII-MJ DIMENSIONS

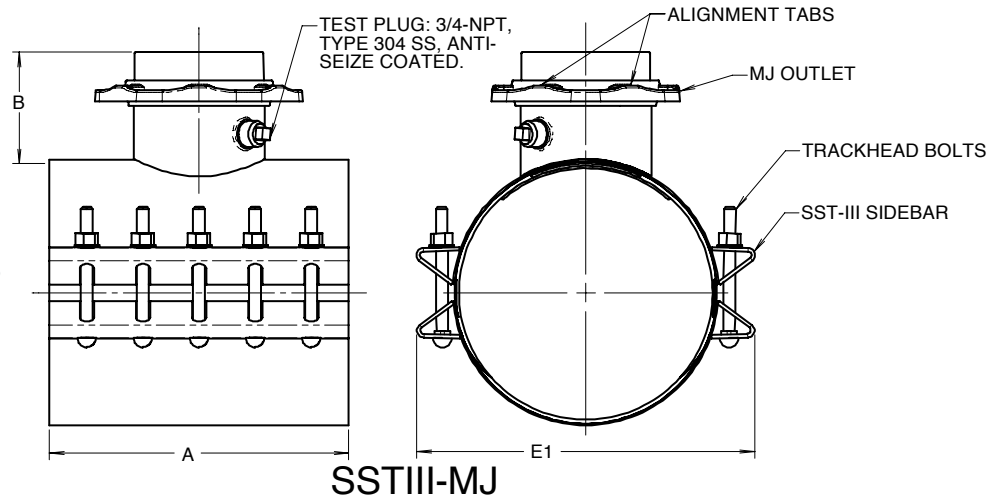
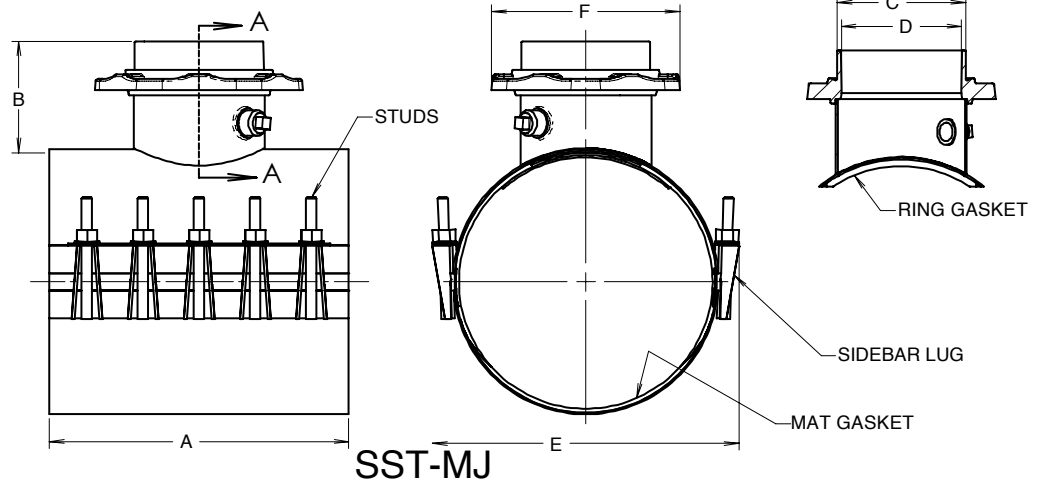

| DIMENSIONS | | | | | | | | | |
|-------------|----------------------------|------------|------|------|-------|-------|---------------|---------------|-------|
| FLANGE SIZE | CATALOG NUMBER | # OF BOLTS | A | B | C | D | E | E1 | F |
| 4" | 4.60 - 5.30 | 8 | 12.0 | 5.88 | 4.80 | 4.33 | PIPE OD + 3.0 | PIPE OD + 4.6 | 9.12 |
| | 5.60 - 19.30 | 10 | 16.0 | | | | | | |
| | 19.70 - 26.50 | 14 | 20.0 | | | | | | |
| | 27.80 - 32.00 ¹ | 21 | 20.0 | | | | | | |
| 6" | 7.00 - 17.95 | 10 | 16.0 | 6.88 | 6.90 | 6.43 | PIPE OD + 3.0 | PIPE OD + 4.6 | 11.12 |
| | 18.25 - 26.50 | 14 | 20.0 | | | | | | |
| | 27.80 - 32.00 ¹ | 21 | 20.0 | | | | | | |
| 8" | 8.63 - 26.50 | 14 | 20.0 | 7.00 | 9.05 | 8.52 | PIPE OD + 3.0 | PIPE OD + 4.6 | 13.40 |
| | 27.80 - 32.00 ¹ | 21 | 20.0 | | | | | | |
| 10" | 10.73 - 26.50 | 16 | 24.0 | 7.50 | 11.10 | 10.51 | PIPE OD + 3.0 | PIPE OD + 4.6 | 15.70 |
| | 27.80 - 32.00 ¹ | 24 | 24.0 | | | | | | |
| 12" | 13.30 - 16.78 | 20 | 30.0 | 7.63 | 13.20 | 12.54 | PIPE OD + 3.0 | PIPE OD + 4.6 | 18.10 |
| | 17.55 - 26.50 | 20 | 30.0 | | | | | | |
| | 27.80 - 32.00 ¹ | 30 | 30.0 | | | | | | |

¹ SSTIII Only

- 6.25 & 6.60 sizes not available with 6" branch.
- 8.30 size not available with 8" branch.
- 10.73 size not available with 10" branch
- 12.75 - 12.90 sizes: 1/2" undersize cutter recommended.