

# 5935™ PIPE DRILLING MACHINE



Transmate

a Division of Romac Industries, Inc.

## MATERIAL SPECIFICATIONS

- Weighs approximately 40 lbs.
- 3/4" to 2" range of cuts using a corporation stop and saddle
- Cuts all types of water mains, wet and dry



3/4" TO 2" RANGE OF CUTS

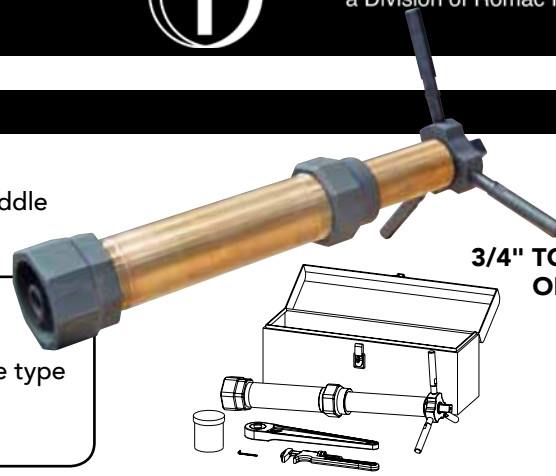

**TO ORDER:**

1. Order Base Machine
2. Order Drills or Holesaws per desired cut size and pipe type
3. Order Adapters
4. Order Power Option if desired

ITEM NUMBER	DESCRIPTION	LIST PRICE
<b>355-00</b>	<b>5935 Pipe Drilling Machine</b>	<b>\$2,429.55</b>
	Included with 5935 Machine:	
355-60-4	Adjustable Wrench SPUD	included
355-60-1	Ratchet Wrench	included
355-61	Tool Box	included
355-60-3	1/8" Allen Wrench	included
353-10-1	Tapping Compound	included
<b>DRILL</b>		
	<b>For Ductile, Cast Iron, A/C &amp; Steel</b>	
354-01-06	3/4" Drill: 5933 (actual OD 11/16")	175.59
	Requires Drill Adapter 355-12-06	
355-01-408	1" Drill: 5937-1 (actual OD 7/8")	440.50
355-01-410	1 1/4" Drill: 5937-1 (actual OD 1 1/8")	444.94
355-01-412	1 1/2" Drill: 5937 (actual OD 1 7/16")	448.22
355-01-416	2" Drill: 5937-1 (actual OD 1 3/4")	592.48
355-04-4	2.5 Drill Extension (Used when doing a 2" tap through a threaded gate valve)	238.88
<b>PVC</b>		
351-01-206	3/4" PVC Cutter (actual OD 11/16")	131.40
351-01-208	1" PVC Cutter (actual OD 15/16")	134.37
351-01-210	1 1/4" PVC Cutter (actual OD 1 1/8")	147.82
351-01-212	1 1/2" PVC Cutter (actual OD 1 3/8")	161.23
351-01-216	2" PVC Cutter (actual OD 1 7/8")	174.68
355-12-06	Adapter: 5938 (required for 3/4", 1" and 1 1/4" PVC cutters. Adapter comes with, and requires the use of PVC Adapter: 354-04-3)	392.79
355-04-3	Large PVC Adapter: 9546 (Required for 1 1/2" & 2" PVC Cutters)	190.34

ITEM NUMBER	DESCRIPTION	LIST PRICE
<b>ADAPTERS</b>		
355-05-406	3/4" Female Iron Pipe Adapter: 5936-3	\$259.57
355-05-408	1" Female Iron Pipe Adapter: 5936-3	259.57
355-05-410	1 1/4" Female Iron Pipe Adapter: 5936-3	259.57
355-05-412	1 1/2" Female Iron Pipe Adapter: 5936-1	259.57
355-05-416	2" Female Iron Pipe Adapter: 5936-1	259.57
355-05-420	2 1/2" Female Iron Pipe Adapter: 5936-1	259.57
355-05-506	3/4" Coarse Thread Compression Adapter: 5936-2	259.57
355-05-508	1" Coarse Thread Compression Adapter: 5936-2	259.57
355-05-510	1 1/4" Coarse Thread Compression Adapter: 5936-2	259.57
355-05-512	1 1/2" Coarse Thread Compression Adapter: 5936	242.59
355-05-706	3/4" Fine Thread Compression	276.87
355-05-708	1" Fine Thread Compression	276.87
355-05-712	1 1/2" Fine Thread Compression	276.87
355-05-716	2" Fine Thread Compression	276.87

**\* Special Adapters can be made per request \***

Note: Female Adapters thread into Part No. 355-37 except the 2 1/2" Female Iron Pipe Adapter which will replace Part No. 355-37. The 355-37 fits 2" Flare Copper Corporation Stops, no 2" Coarse Thread Compression is required.

ITEM NUMBER	DESCRIPTION	LIST PRICE
<b>TAPPING COMPOUND</b>		
353-10-1	Tapping Compound	33.90
353-10-3	Tapping Compound / Case (12)	390.95

ITEM NUMBER	DESCRIPTION	LIST PRICE
<b>POWER OPTION</b>		
373-355	Ridgid 690 Electric Drive w/ 7/8" sq. drive adapter See pg. TM-28	3,075.52
370-70	GF-15 Ground Fault Interrupter Plug (required)	131.61

**5935 PARTS INCLUDED WITH 5935 DRILLING MACHINE**

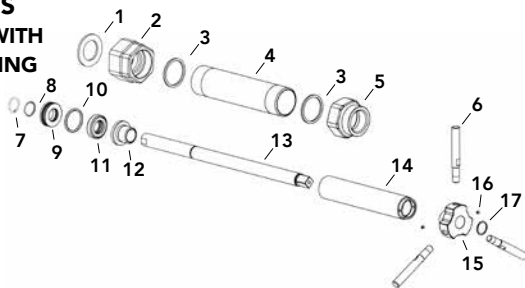

REF. NO.	DESCRIPTION	ITEM NUMBER	LIST PRICE
1	Adapter Gasket	355-57-05	\$ 16.23
2	Bottom Cylinder Coupling	355-37	219.76
3	Top & Bottom Cylinder Gaskets (2 req.)	355-38-57	ea. 11.67
4	Cylinder	355-38	\$210.42

REF. NO.	DESCRIPTION	ITEM NUMBER	LIST PRICE
5	Top Cylinder Coupling	355-36	363.40
6	Handle for Lead Nut (3 req.)	350-29	ea. 98.78
7	Shaft End Snap Ring	350-20-54	12.72
8	Collar O-Ring (inside)	355-40-5711	2.25
9	Collar	355-40	106.84
10	Collar O-Ring (outside)	355-40-5712	2.25
11	Thrust Bearing	355-56	44.57
12	Feed Screw (bottom)	355-43-2	135.95
13	Drill Holder	355-12	333.11
14	Feeder Screw	355-43	420.16
15	Tri-Handle Holder	355-29-1	207.65
16	Set Screw	351-23-512	1.32
17	Spiral Snap Ring	355-54	6.66
	Not Illustrated:		
	Ratchet Wrench	355-60-1	369.42
	Adjustable Wrench	355-60-4	113.81
	1/8" Allen Wrench	355-60-3	3.01
	Tapping Compound	353-10-1	33.90
	Tool Box	355-61	223.37

Drill Holders, Drills, Holesaws, PVC Adapters, Cutter Adapters, Pilot Drills and Machine Adapters are ordered separately (see above).

TRANSMATE