

101NU & 202NU / 101NSSU & 202NSSU SERVICE SADDLES

SUBMITTAL INFORMATION

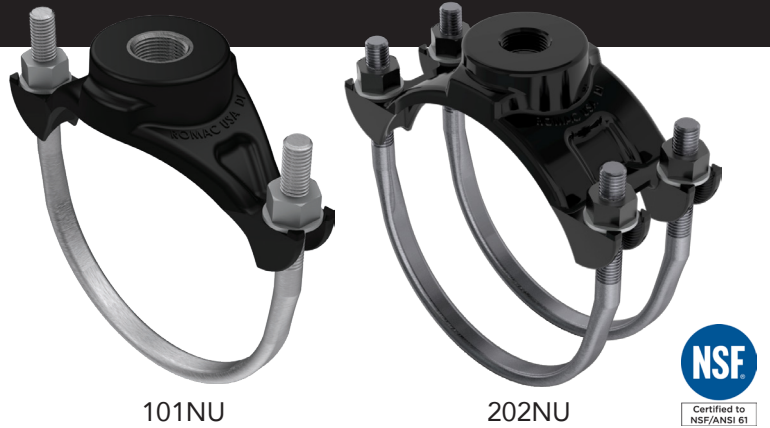

101NU

202NU

MATERIALS

CASTING

The saddle body is cast from ductile (nodular) iron, meeting or exceeding ASTM A 536, Grade 65-45-12.

GASKET

Gasket is made from Nitrile Butadiene Rubber (NBR) compounded for water and sewer service and a tolerance of petroleum products in accordance with ASTM D 2000 MBC 610 and NSF 61 Certified. Other compounds available for special applications.

COATING

Casting is coated with fusion bonded black nylon, 10-14 mils thick, with a dielectric strength of 1,000 v/mil and NSF 61 Certified.

U BOLT, NUTS & WASHERS

Sizes 1-1/2" through 3", use 1/2" U bolt with heavy hex nuts and 1/2" flat washers, 4" and above use 5/8" U bolt with heavy hex nut and 5/8" flat washers. All sizes are national coarse roll threaded. Steel meets AISI C1018 and is electro-galvanized.

101NU & 202NU: Steel meets AISI C1018 and is electro-galvanized.

101NSSU & 202NSSU: Steel meets ASTM A276 Type 316 stainless.

PRESSURE

Ductile iron, cast iron and steel pipe: rating of pipe up to 350 psi maximum. For other applications please consult your representative.

STANDARD

Contact Romac Engineering for ANSI/AWWA C800 Spec and Approval Chart.

SIZES & RANGES

See Catalog.

05/23/22

Document # 25-8-0009

This information is based on the best data available at the date printed above. Please check with Romac for any updates or changes.