

REVISIONS			
REV	DESCRIPTION	DATE	EDITOR
9	ADDED DIMENSION FROM END OF PIPE TO FACE OF MJ.	09/19/12	PNN
10	PRESSURE RATINGS REMOVED, NOTE 2 REMOVED.	11/15/19	DJS
11	CORRECTED NOTE 4 REFERENCE.	11/11/24	MSL

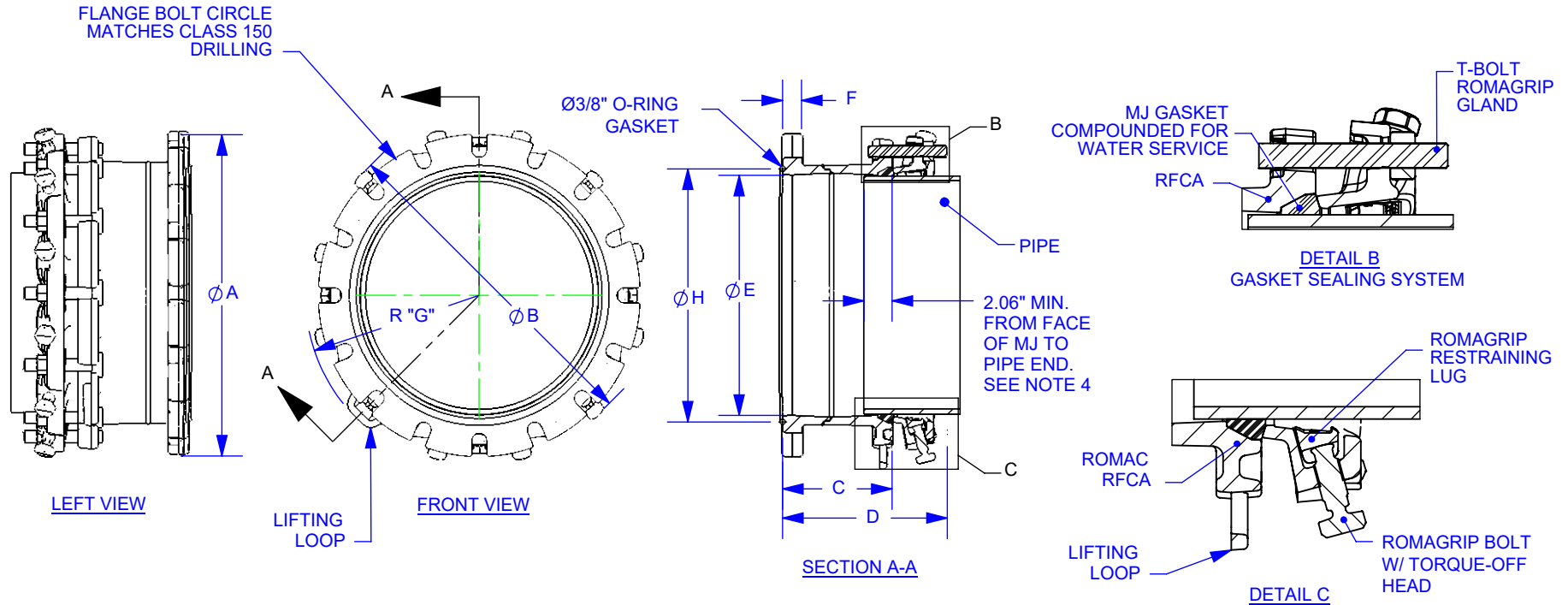

NOTES

1. COATING OPTIONS: BODY - SHOP COAT OR NSF61 CERTIFIED FUSION BONDED EPOXY, ROMAGRIP - CAN BE SHOP COAT OR ROMABOND POLYESTER.
2. DUCTILE IRON AND T-BOLTS PER AWWA C111. STAINLESS STEEL FASTENERS AVAILABLE. WHEN STAINLESS STEEL, THREADED ROD AND TWO NUTS ARE SUPPLIED IN LIEU OF T-BOLTS.
3. THE RFCA IS FOR USE ON DUCTILE IRON PIPE. THE RFCA-PVC IS REQUIRED FOR USE ON PVC PIPE.
4. THE MINIMUM PIPE INSERTION IS 2.06" PAST FACE OF MJ BODY END (1.0" PAST GASKET), AT BOTH ZERO DEFLECTION AND AT MAX DEFLECTION VALUES (SEE TABLE).

NOM. SIZE	DEFL. (deg)	FLG	RG	T BOLTS			DIMENSIONS						WGTL, LBS
		OD	MAX	QTY	SIZE	LGTH	C	D	E	F	G	H (O-RING)	
14	2.0	21.0	22.0	10	3/4"	4.5	8.00	11.70	15.44	1.38	11.59	16.38	170
16	2.0	23.5	24.1	12	3/4"	4.5	8.00	11.70	17.54	1.44	12.72	18.48	200
18	1.5	25.0	26.3	12	3/4"	4.5	8.00	11.80	19.64	1.45	13.88	20.57	217
20	1.5	27.5	28.4	14	3/4"	4.5	8.00	11.80	21.74	1.47	14.63	22.63	256
24	1.5	32.0	32.6	16	3/4"	5.0	8.00	12.00	25.94	1.50	17.06	26.88	305

<p>PROPRIETARY NOTICE</p> <p>THIS DRAWING CONTAINS CONFIDENTIAL PROPRIETARY INFORMATION AND IS THE PROPERTY OF ROMAC IND., INC. IT IS TO BE USED ONLY FOR THE PURPOSE FOR WHICH IT WAS SUBMITTED AND SHALL NOT HAVE IT'S INFORMATION DISCLOSED OR REPRODUCED IN WHOLE OR IN PART FOR ANY PURPOSE WITHOUT PRIOR WRITTEN PERMISSION OF ROMAC IND., INC.</p>	<p>UNLESS OTHERWISE SPECIFIED</p> <p>DIMENSIONS ARE IN INCHES</p> <p>TOLERANCES ARE ON:</p> <p>1 PL DECIMALS ±</p> <p>2 PL DECIMALS ±</p> <p>3 PL DECIMALS ±</p> <p>ANGLES ±</p> <p>FRACTIONS ±</p>	<p>SIGNATURES</p> <p>DRAWN NIELS THOGERSEN III 01/11/02</p>			<p>ROMAC INDUSTRIES INC., BOTHELL, WA</p>			
		<p>CHECKED 11/14/24</p>			<p>TITLE 14" - 24" RFCA & RFCA-PVC RESTRAINED FLANGED COUPLING ADAPTER</p>			
		<p>APPROVAL ORGANIZATIONS ENGINEERING</p>			<p>DWG. NO. B1950-A</p>	<p>SIZE A</p>	<p>REV. NO. 11</p>	<p>SCALE NTS</p>