

B1899-A

NOTES:

1. DUCTILE IRON, ASTM 536, GRADE 65-45-12
2. FASTENERS OF TYPE 304 OR 316 STAINLESS STEEL OPTIONAL
3. GASKETS OF NBR OR EPDM OPTIONAL
4. SHOP COAT STANDARD, FUSION EPOXY OPTIONAL
5. ALL DIMENSIONS IN INCHES
6. WORKING PRESSURE UP TO 260 PSI. PIPE ODS SMALLER THAN STD STEEL SIZE NOT TO EXCEED 20 PSIG

REVISIONS			
REV.	DESCRIPTION	DATE	APPROVED
1	ADD 10 & 12 INCH SIZES	8/1/02	GFD
2	PIPE MIN DIA CHANGED ADDED NOTE 6	8/15/07	CJS

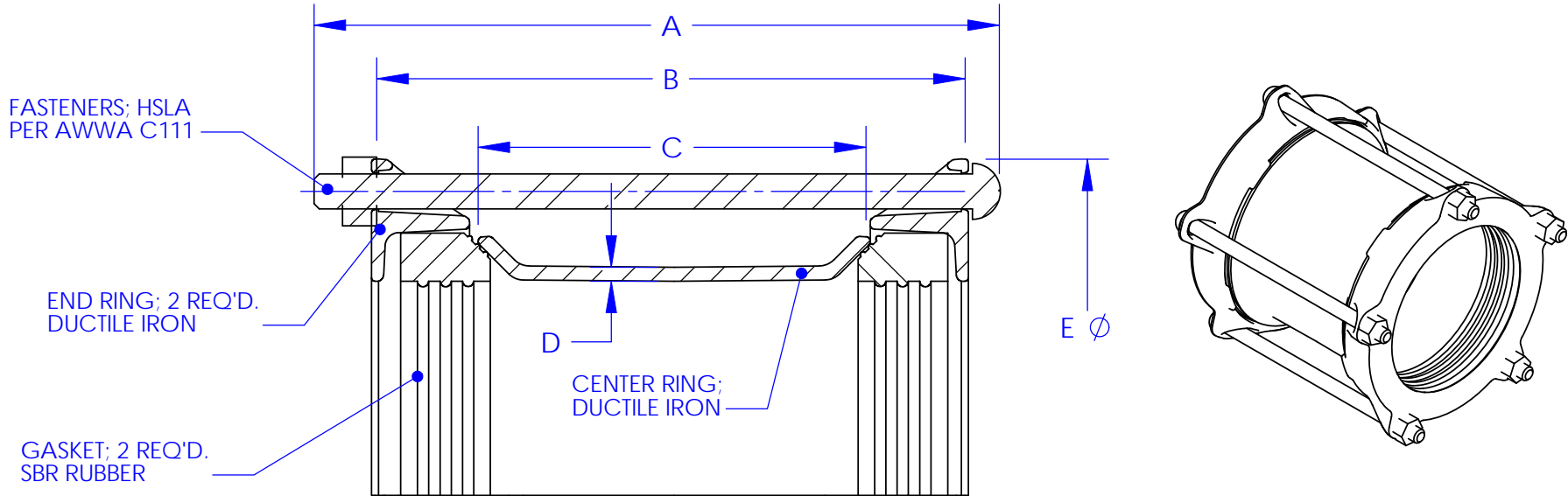

NOMINAL SIZE	A	B	C	D	E	BOLTS			PIPE DIAMETER	
						NO.	DIA.	LENGTH	MIN.	MAX.
4	12.0	10.1	7.0	0.25	10.1	4	5/8	11 1/2	4.215	5.60
6	12.0	10.1	7.0	0.25	12.1	5	5/8	11 1/2	6.275	7.60
8	12.0	10.5	7.0	0.25	15.3	6	5/8	11 1/2	8.400	9.75
10	13.5	11.7	8.0	0.25	17.5	6	5/8	13	10.500	12.15
12	13.5	11.9	8.0	0.25	20.1	8	5/8	13	12.500	14.41

<p>PROPRIETARY NOTICE</p> <p>THIS DRAWING CONTAINS CONFIDENTIAL PROPRIETARY INFORMATION AND IS THE PROPERTY OF ROMAC IND., INC. IT IS TO BE USED ONLY FOR THE PURPOSE FOR WHICH IT WAS SUBMITTED AND SHALL NOT HAVE ITS INFORMATION DISCLOSED OR REPRODUCED IN WHOLE OR IN PART FOR ANY PURPOSE WITHOUT PRIOR WRITTEN PERMISSION OF ROMAC IND., INC.</p>	<p>UNLESS OTHERWISE SPECIFIED</p> <p>DIMENSIONS ARE IN INCHES</p> <p>TOLERANCES ARE ON: 1 PL DECIMALS $\pm .060$ 2 PL DECIMALS $\pm .030$ 3 PL DECIMALS $\pm .010$ ANGLES $\pm 1^\circ$ FRACTIONS $\pm 1/64$</p>	SIGNATURES			<p>ROMAC INDUSTRIES INC., BOTHELL, WA</p>				
		DRAWN			TITLE				
		CHECKED			XR501 COUPLING 4 - 12 INCH				
APPROVAL ORGANIZATIONS PROP.CUST.APP. ORG.		DWG. NO.	SIZE	REV. NO.	SCALE	SHEET			
		B1899-A	A	2	NTS	1 OF 1			