

NOMINAL SIZE (IN)	PIPE OD RANGE (IN)	RADIUS (IN)	LENGTH (IN) A	WIDTH (IN)	HEIGHT (IN)
2	2.38 - 2.50	1.25	4.86	3.31	1.35
3	3.50	1.75	6.50	4.00	1.32
	3.45 - 4.05	2.03	7.15	3.31	1.35
4	4.00 - 4.50	2.25	6.98	4.00	1.50
	4.50 - 4.80	2.40	7.12	4.00	1.50
	4.50 - 5.40	2.70	7.63	4.00	1.50
6	6.00 - 6.63	3.32	8.96	4.00	1.50
	6.63 - 6.90	3.45	9.10	4.00	1.50
	6.63 - 7.60	3.80	9.97	4.00	1.50
8	8.00 - 8.63	4.32	10.69	4.00	1.50
	8.63 - 9.05	4.53	11.12	4.00	1.50
	8.63 - 9.80	4.90	11.80	4.00	1.50
10	10.00 - 11.10	5.55	13.13	4.00	1.50
	11.10 - 12.12	6.06	14.12	4.00	1.50
12	12.00 - 13.20	6.60	15.17	4.00	1.50
	13.20 - 14.38	7.19	16.32	4.00	1.50

REVISIONS			
REV.	DESCRIPTION	DATE	EDITOR
R2	A	UPDATED ALL LENGTHS.	6/20/22
	B	REMOVED NYLON THICKNESS.	

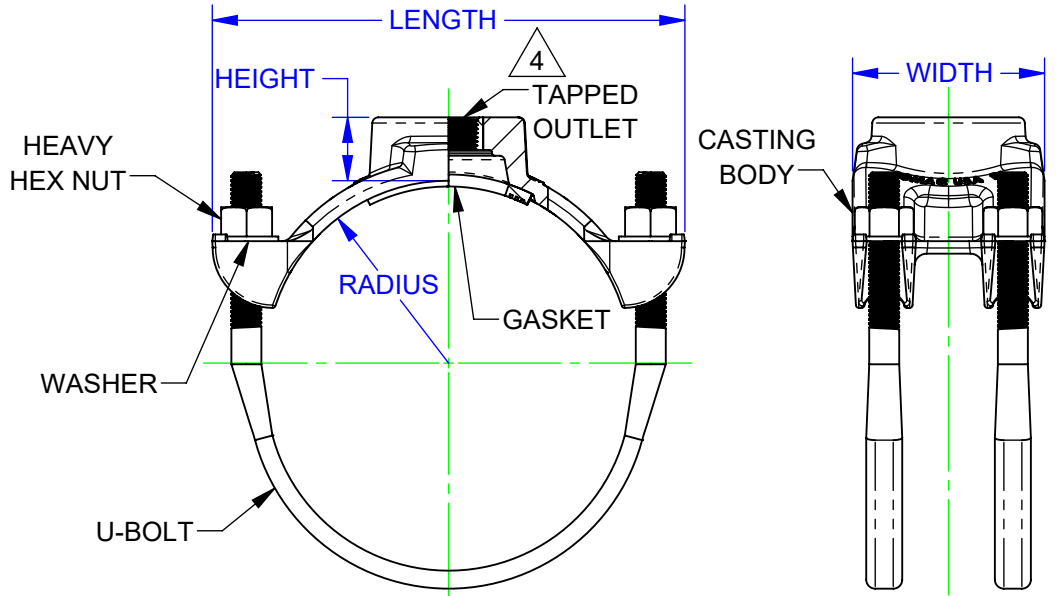

NOTES:

- CASTING BODY: DUCTILE IRON PER ASTM A536 65-45-12.
- U-BOLT: ZINC-PLATED STEEL PER AISI C1018.
 - 3" AND SMALLER: 1/2-13 UNC THREAD.
 - 4" AND LARGER: 5/8-11 UNC THREAD.
 - 316 STAINLESS STEEL AVAILABLE UPON REQUEST.
 - U-BOLT IS NOT RECOMMENDED FOR USE ON PVC PIPE.
- NUT & WASHER: TYPE 304 STAINLESS STEEL.
- OUTLET: REFER TO CATALOG FOR AVAILABLE "IP" (NPT) OR "CC" (PER AWWA C800) TAP SIZES.
- GASKET: NBR PER ASTM D2000 MBC 610. EPDM AVAILABLE UPON REQUEST.
- COATING:
 - 202U & 202SSU: SHOP COAT ENAMEL
 - 202NU & 202NSSU: NYLON COATING **B**
 - NUTS: BLACK EPOXY E-COAT

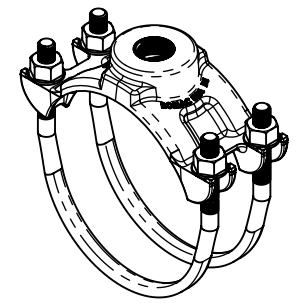

FOR CUSTOMER USE **A**

RELEASED **B**

<p>PROPRIETARY NOTICE</p> <p>THIS DRAWING CONTAINS CONFIDENTIAL PROPRIETARY INFORMATION AND IS THE PROPERTY OF ROMAC IND., INC. IT IS TO BE USED ONLY FOR THE PURPOSE FOR WHICH IT WAS SUBMITTED AND SHALL NOT HAVE ITS INFORMATION DISCLOSED OR REPRODUCED IN WHOLE OR IN PART FOR ANY PURPOSE WITHOUT PRIOR WRITTEN PERMISSION OF ROMAC IND., INC.</p>		<p>UNLESS OTHERWISE SPECIFIED</p> <ul style="list-style-type: none"> DIMENSIONS ARE IN INCHES DRAWING NOT TO SCALE. 		<p>SIGNATURES</p> <p>DRAWN Kevin Tam</p> <p>APPROVED Tanja Parviainen</p>		<p>DATE</p> <p>06/20/2022</p> <p>6/21/2022</p>		<p>ROMAC INDUSTRIES INC.</p> <p>TITLE DI SADDLES 202U SNU NU NSSU, 2" - 12"</p>											
<p>MODEL NAME: SERVICE SADDLE, ASSEM, DI, 202, 07.60 IN MODEL CAD #: CAD-050490</p>		<p>CONFIGURATION NAME: U-Bolt</p>		<p>THIRD ANGLE PROJECTION</p>		<p>LEGACY DRAWING #: B2621-A DRAWING FILE NAME: SERVICE SADDLE, ASSEM, DI, 202, U-BOLT, 2 - 12 IN</p>		<p>DWG. NO. CAD-053030</p>		<p>SIZE A</p>		<p>REV. NO. R2</p>		<p>SCALE NTS</p>		<p>SHEET 1 OF 1</p>		<p>AUTHOR: Kevin Tam</p>	