

NOMINAL SIZE (IN)	PIPE OD RANGE (IN)	RADIUS (IN)	LENGTH (IN)
4	4.00 - 4.50	2.25	6.85
	4.50 - 4.80	2.40	6.99
	4.50 - 5.40	2.70	7.51
6	6.00 - 6.63	3.32	8.84
	6.63 - 6.90	3.45	8.98
	6.63 - 7.60	3.80	9.85
8	8.00 - 8.63	4.32	10.58
	8.63 - 9.05	4.53	11.00
	8.63 - 9.80	4.90	11.68
10	10.00 - 11.10	5.55	13.00
	11.10 - 12.12	6.06	14.00
12	12.00 - 13.20	6.60	15.05
	13.20 - 14.38	7.19	16.19
14	15.30 - 16.80	8.40	11.93
16	17.40 - 18.90	9.45	12.62
18	19.50 - 21.10	10.55	12.71
20	21.10 - 22.70	11.35	12.76
22	22.70 - 24.30	12.15	14.58
24	24.30 - 25.90	12.95	14.64
26	25.70 - 27.30	13.65	14.68
28	27.30 - 28.90	14.45	14.72
30	28.90 - 30.50	15.25	14.75
	30.50 - 32.10	16.05	14.78

REVISIONS			
REV.	DESCRIPTION	DATE	EDITOR
R1	A	4/13/22	RBA
UPDATED NYLON COATING THICKNESS FROM 10-12 TO 10-14			

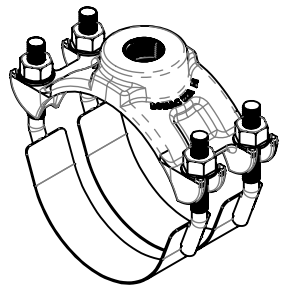
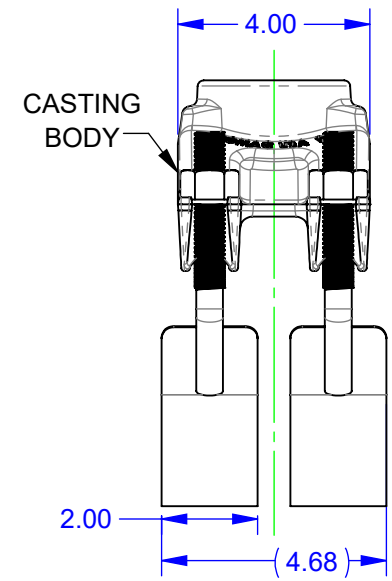
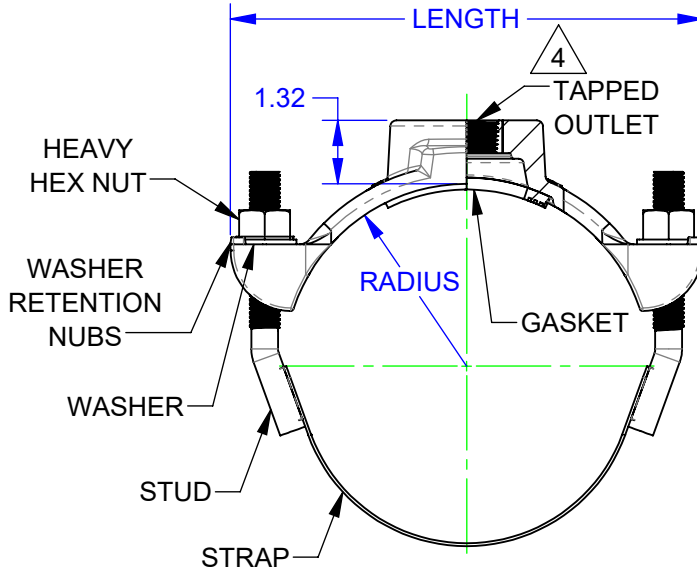

- NOTES:
- CASTING BODY: DUCTILE IRON PER ASTM A536 65-45-12.
  - STRAP, STUD, & NUT: TYPE 304 STAINLESS STEEL.
  - STUD & NUT: 5/8-11 UNC.
  - OUTLET: UP TO 2.5" "IP" (NPT) OR 2" "CC" (PER AWWA C800) TAP SIZES.
  - GASKET: NBR PER ASTM D2000 MBC 610. EPDM AVAILABLE UPON REQUEST.
  - WELDING: GMAW. CHEMICALLY CLEANED AND PASSIVATED.
  - COATING:
    - 202S: SHOP COAT ENAMEL
    - 202NS: NYLON COATING 10-14 MILS THICK
    - NUTS: BLACK EPOXY E-COAT

FOR CUSTOMER USE

RELEASED

<b>PROPRIETARY NOTICE</b> THIS DRAWING CONTAINS CONFIDENTIAL PROPRIETARY INFORMATION AND IS THE PROPERTY OF ROMAC IND., INC. IT IS TO BE USED ONLY FOR THE PURPOSE FOR WHICH IT WAS SUBMITTED AND SHALL NOT HAVE ITS INFORMATION DISCLOSED OR REPRODUCED IN WHOLE OR IN PART FOR ANY PURPOSE WITHOUT PRIOR WRITTEN PERMISSION OF ROMAC IND., INC.		<b>UNLESS OTHERWISE SPECIFIED</b> • DIMENSIONS ARE IN INCHES • DRAWING NOT TO SCALE.		<b>SIGNATURES</b> DRAWN Rosa Bartsch APPROVED Caitlin Boone		<b>DATE</b> 4/13/2022 4/13/2022		<b>ROMAC INDUSTRIES INC.</b> TITLE DI SADDLES 202S & 202NS, 4" - 30"						
MODEL NAME: SERVICE SADDLE, ASSEM, DI, 202, 07.60 IN MODEL CAD #: CAD-050490		CONFIGURATION NAME: Strap		THIRD ANGLE PROJECTION		LEGACY DRAWING #: CAD-021165 DRAWING FILE NAME: SERVICE SADDLE, ASSEM, DI, 202, STRAP, 4 - 30 IN		DWG. NO. CAD-053015		SIZE A	REV. NO. R1	SCALE NTS	SHEET 1 OF 1	AUTHOR: Kevin Tam