

REVISIONS			
REV.	DESCRIPTION	DATE	EDITOR
0	INITIAL RELEASE	'15 SEP 28	DH EATON

HEAVY HEX NUTS
COATED TO PREVENT
GALLING

WASHER

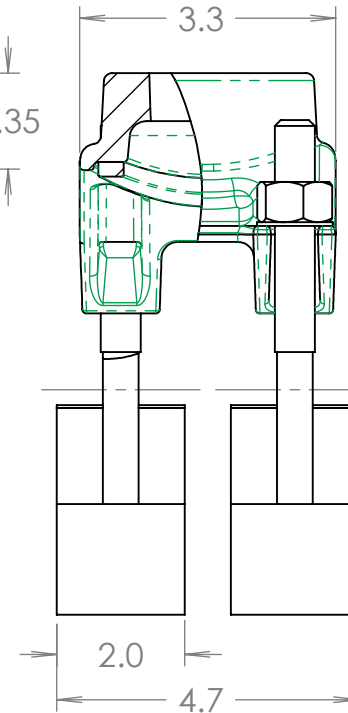
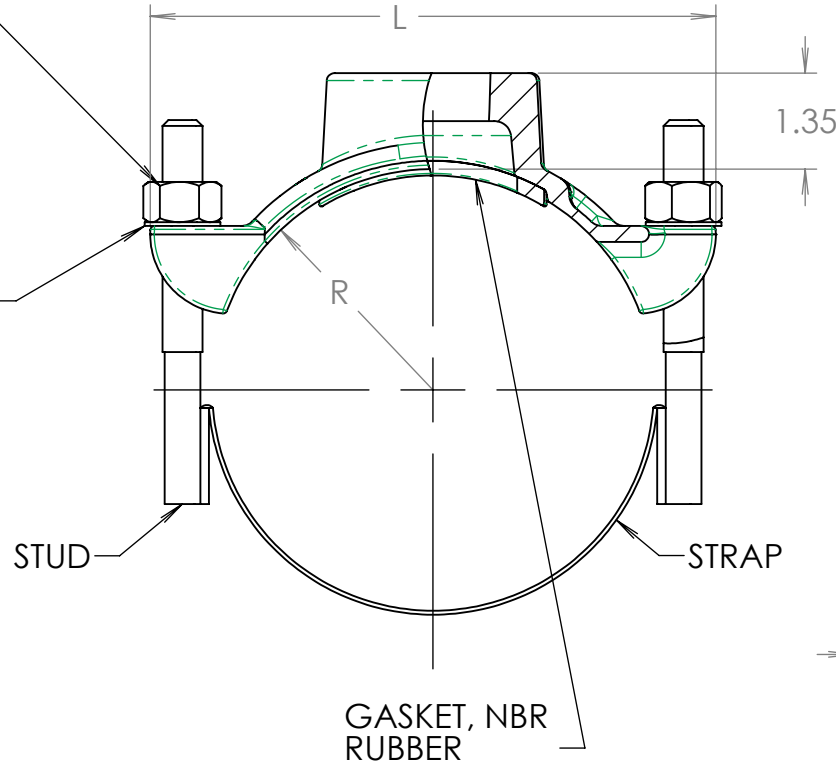

NOTE:

1. BODY: DUCTILE IRON PER ASTM A536 GRD 65-45-12.
2. COATING: NYLON, 10-12 MILS THICK.
3. THREAD: "IP" (NPT) OR "CC" PER AWWA C800 AVAILABLE.
4. STRAP, STUD, AND NUT: TYPE 304 STAINLESS STEEL:
 - WELDING: GMAW AND GTAW. CHEMICALLY CLEANED AND PASSIVATED.
 - 1/2-NC ROLL THREAD, WITH HEAVY HEX NUTS AND 1/2" FLAT WASHER.

DIMENSIONS					
NOM. SIZE	PIPE OD RANGE	L	R	H	W
2"	2.38 - 2.50	4.88	1.25	1.35	3.31
3"	3.50	5.94	1.75	1.35	3.31
	3.45 - 4.05	6.38	2.21	1.35	3.31

<p>PROPRIETARY NOTICE</p> <p>THIS DRAWING CONTAINS CONFIDENTIAL PROPRIETARY INFORMATION AND IS THE PROPERTY OF ROMAC IND., INC. IT IS TO BE USED ONLY FOR THE PURPOSE FOR WHICH IT WAS SUBMITTED AND SHALL NOT HAVE ITS INFORMATION DISCLOSED OR REPRODUCED IN WHOLE OR IN PART FOR ANY PURPOSE WITHOUT PRIOR WRITTEN PERMISSION OF ROMAC IND., INC.</p>	<p>UNLESS OTHERWISE SPECIFIED</p> <p>DIMENSIONS ARE IN INCHES</p> <p>TOLERANCES ARE ON:</p> <p>1 PL DECIMALS ±</p> <p>2 PL DECIMALS ±</p> <p>3 PL DECIMALS ±</p> <p>ANGLES ± °</p> <p>FRACTIONS ±</p>	<p>SIGNATURES</p> <p>DRAWN</p> <p>Del Eaton</p> <p>APPROVED</p> <p>Peter Nielsen</p>	<p>DATE</p> <p>09/28/2015</p> <p>9/29/2015</p>	<p></p> <p>ROMAC INDUSTRIES INC.</p> <p>TITLE</p> <p>202S AND 202NS SADDLES 2" - 3"</p>
<p>MODEL NAME: 202N-S ASSY</p> <p>CONFIGURATION NAME: Default</p>	<p>MODEL CAD #: CAD-023191</p>	<p>LEGACY DRAWING #:</p> <p>DWG. NO. CAD-023239</p> <p>DRAWING FILE NAME: 202S-202N 2-3 CUST DWG</p>	<p>SIZE A</p> <p>REV. NO. R0</p> <p>SCALE 1:3</p> <p>SHEET 1 OF 1</p>	<p>AUTHOR: Del Eaton</p>