

REVISIONS			
REV.	DESCRIPTION	DATE	EDITOR
0	INITIAL RELEASE	'15 SEP 28	DEL EATON

HEAVY HEX NUTS
COATED TO PREVENT
GALLING

WASHER

STUD

STRAP

GASKET, NBR
RUBBER

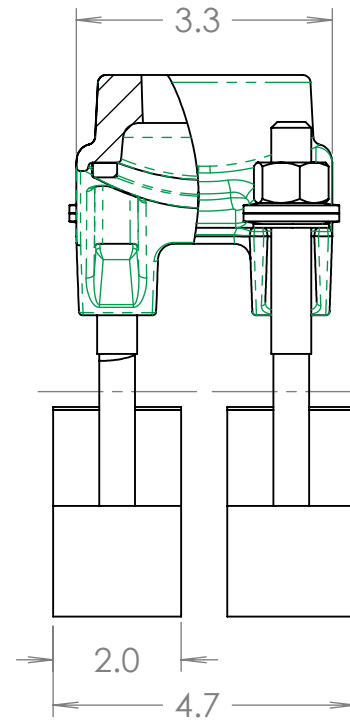
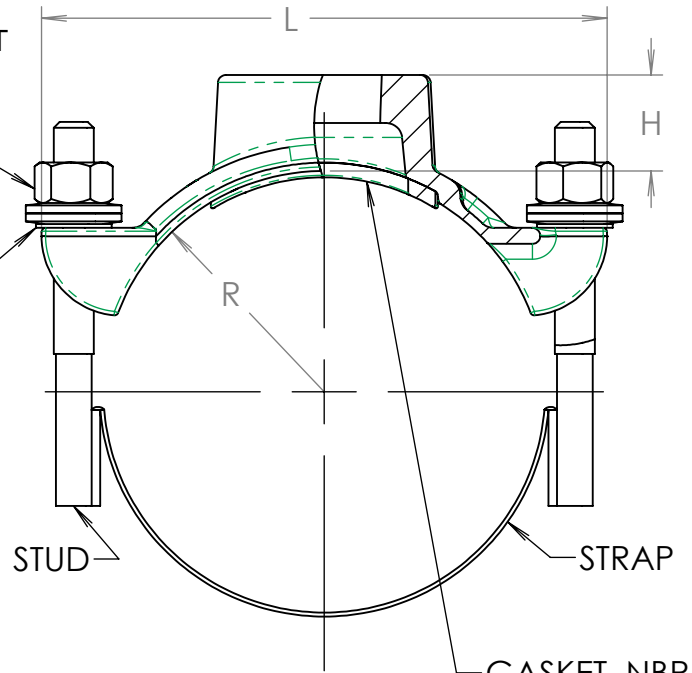

NOTE:

1. BODY: DUCTILE IRON PER ASTM A536 GRD 65-45-12.
2. COATING: NYLON, 10-12 MILS THICK.
3. THREAD: "IP" (NPT) OR "CC" PER AWWA C800 AVAILABLE.
4. STRAP, STUD, AND NUT: TYPE 304 STAINLESS STEEL:
 - WELDING: GMAW AND GTAW. CHEMICALLY CLEANED AND PASSIVATED.
 - 1/2-NC ROLL THREAD, WITH HEAVY HEX NUTS AND 1/2" FLAT WASHER.
5. SADDLES NOT TO BE USED ON HDPE PIPE WITH SDR GREATER THAN 26

DIMENSIONS				
NOM. SIZE	PIPE O.D.	L	R	N
2"	2.13	4.88	1.25	2
2"	2.38	4.88	1.25	2
3"	3.50	5.94	1.75	2

<p>PROPRIETARY NOTICE</p> <p>THIS DRAWING CONTAINS CONFIDENTIAL PROPRIETARY INFORMATION AND IS THE PROPERTY OF ROMAC IND., INC. IT IS TO BE USED ONLY FOR THE PURPOSE FOR WHICH IT WAS SUBMITTED AND SHALL NOT HAVE ITS INFORMATION DISCLOSED OR REPRODUCED IN WHOLE OR IN PART FOR ANY PURPOSE WITHOUT PRIOR WRITTEN PERMISSION OF ROMAC IND., INC.</p>	<p>UNLESS OTHERWISE SPECIFIED</p> <p>DIMENSIONS ARE IN INCHES</p> <p>TOLERANCES ARE ON:</p> <p>1 PL DECIMALS ± .0600.020</p> <p>2 PL DECIMALS ± .0300.010</p> <p>3 PL DECIMALS ± .0100.005</p> <p>ANGLES ± 1°</p> <p>FRACTIONS ± 1/64</p>	<p>SIGNATURES</p> <p>Del Eaton</p>	<p>DATE</p> <p>09/28/2015</p>	<p>ROMAC INDUSTRIES INC.</p> <p>TITLE</p> <p>202NH SADDLES</p> <p>2" - 3"</p>
		<p>APPROVED</p> <p>Peter Nielsen</p>	<p>DATE</p> <p>9/29/2015</p>	

MODEL NAME: 202N-S ASSY
CONFIGURATION NAME: 202N-H

MODEL CAD #: CAD-023191



DWG. NO. CAD-023190	SIZE A	REV. NO. R0	SCALE 1:3	SHEET 1 OF 1
------------------------	-----------	----------------	--------------	-----------------

LEGACY DRAWING #: AUTHOR: Del Eaton
DRAWING FILE NAME: 202NH 2-3 CUST DWG