

CAD-021113

General Table

NOMINAL SIZE	O.D. PIPE RANGE	LENGTH (L)	RADIUS (R)	WIDTH (W)
1-1/2"	1.90 - 2.13	4.69	1.07	2.63
2"	2.38 - 2.50	4.50	1.25	
3"	3.45 - 4.05	5.56	2.21	

REVISIONS

REV.	DESCRIPTION	DATE	APPROVED
0	INITIAL RELEASE IN PDM, ADDED STRAP WIDTH	6/4/13	PNN
1	DELETED 4" - 12"	6/8/2015	DHE

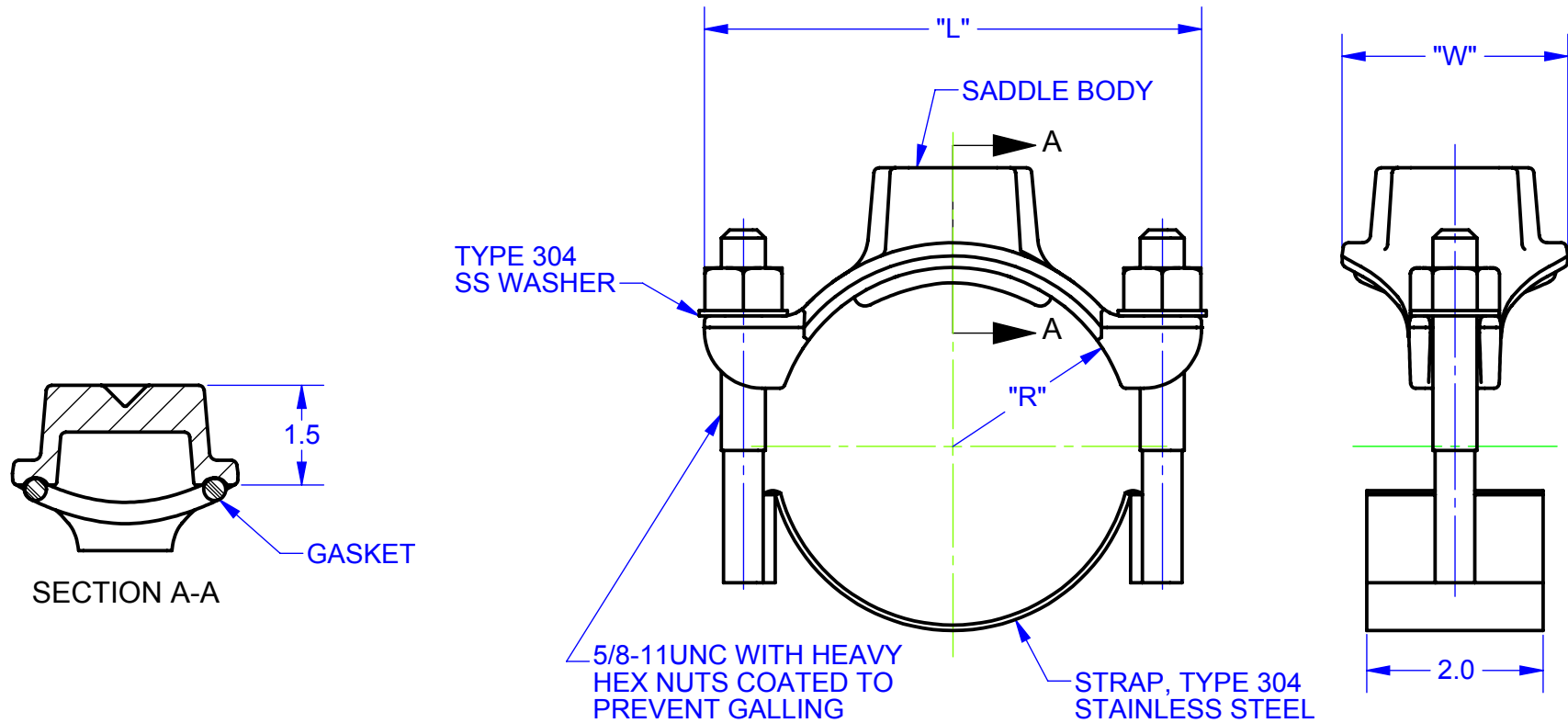

NOTES:

1. ALL MATERIAL DUCTILE IRON PER ASTM A536 GRADE 65-45-12, UNLESS NOTED OTHERWISE.
2. COATING: SHOP COAT (101S) OR NYLON COATING (101NS) 10-12 MILS THICK.
3. THREAD: "IP" (NPT) OR "CC" (PER AWWA C800) AVAILABLE.

PROPRIETARY NOTICE	UNLESS OTHERWISE SPECIFIED	SIGNATURES	DATE		ROMAC INDUSTRIES INC. TITLE 101S&N SADDLE - 1-1/2" - 3"				
THIS DRAWING CONTAINS CONFIDENTIAL PROPRIETARY INFORMATION AND IS THE PROPERTY OF ROMAC IND., INC. IT IS TO BE USED ONLY FOR THE PURPOSE FOR WHICH IT WAS SUBMITTED AND SHALL NOT HAVE ITS INFORMATION DISCLOSED OR REPRODUCED IN WHOLE OR IN PART FOR ANY PURPOSE WITHOUT PRIOR WRITTEN PERMISSION OF ROMAC IND., INC.	DIMENSIONS ARE IN INCHES TOLERANCES ARE ON: 1 PL DECIMALS ± 0.060 2 PL DECIMALS ± 0.030 3 PL DECIMALS ± 0.010 ANGLES ± 1° FRACTIONS ± 1/64	DRAWN Peter Nielsen APPROVED Peter Nielsen	05/28/2013 6/11/2015		DWG. NO. CAD-021113	SIZE A	REV. NO. R0	SCALE 1:2	SHEET 1 OF 1

MODEL NAME: 101S - CUSTOMER DRAWING

MODEL CAD #: CAD-006787

LEGACY DRAWING #: B1507-A

AUTHOR: Peter Nielsen

CONFIGURATION NAME: Default

DRAWING FILE NAME: 101S-101NS 1.5-3 CUST DWG