

FOR CUSTOMER USE

CAD-017539

| NOM. PIPE SIZE | GASKET RANGE   | CR LENGTH | BOLT QTY: | BURNOUT THK: 150 PSI | BURNOUT THK: 260 PSI | OVRL. BOLT LG: | MAX OD |
|----------------|----------------|-----------|-----------|----------------------|----------------------|----------------|--------|
|                |                |           | A         | B                    | B                    | C              | D      |
| 4"             | 4.125* - 5.00  | 7"        | 4         | 0.38                 | 0.38                 | 13.50"         | 10.06  |
|                | 4.215* - 5.60  | 12"       |           |                      |                      | 18.50"         |        |
| 6"             | 6.275* - 7.20  | 7"        | 5         | 0.50                 | 0.63                 | 13.50"         | 12.04  |
|                | 6.275* - 7.60  | 12"       |           |                      |                      | 18.50"         |        |
| 8"             | 8.40* - 9.30   | 7"        | 6         | 0.50                 | 0.75                 | 13.50"         | 14.88  |
|                | 8.40* - 9.75   | 12"       |           |                      |                      | 18.50"         |        |
| 10"            | 10.50* - 11.41 | 8"        | 6         | 0.63                 | 1.0                  | 15.50"         | 17.38  |
|                | 10.50* - 12.15 | 12"       |           |                      |                      | 18.50"         |        |
| 12"            | 12.50* - 13.56 | 8"        | 8         | 0.75                 | 1.0                  | 15.50"         | 20.14  |
|                | 12.50* - 14.41 | 13"       |           |                      |                      | 20.50"         |        |

| REVISIONS |                         |          |          |
|-----------|-------------------------|----------|----------|
| REV.      | DESCRIPTION             | DATE     | APPROVED |
| 1         | GASKET MATERIAL WAS SBR | 3/7/2019 | PNL      |

\*PIPE OD'S SMALLER THAN STANDARD STEEL SIZE, NOT TO EXCEED 20 PSI.

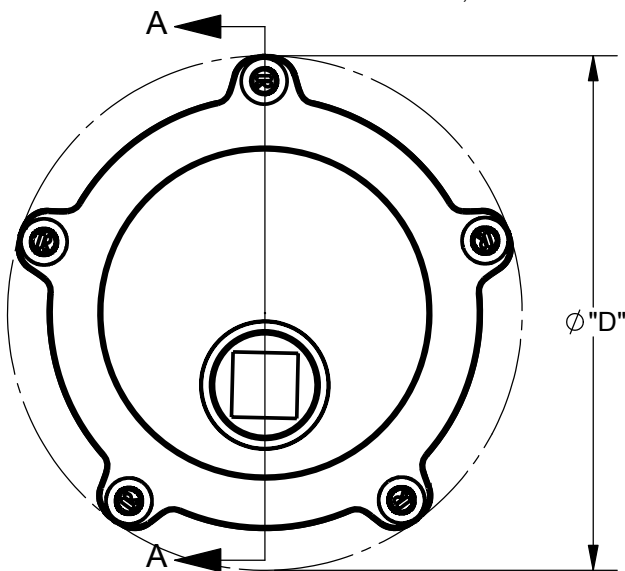

TRACKHEAD 5/8" X 11 UNC,  
QTY: "A"

BURNOUT,  
"B" THK,  
A36 STEEL,  
QTY: 1

2" NPT PLUG,  
SQR HEAD  
QTY:1

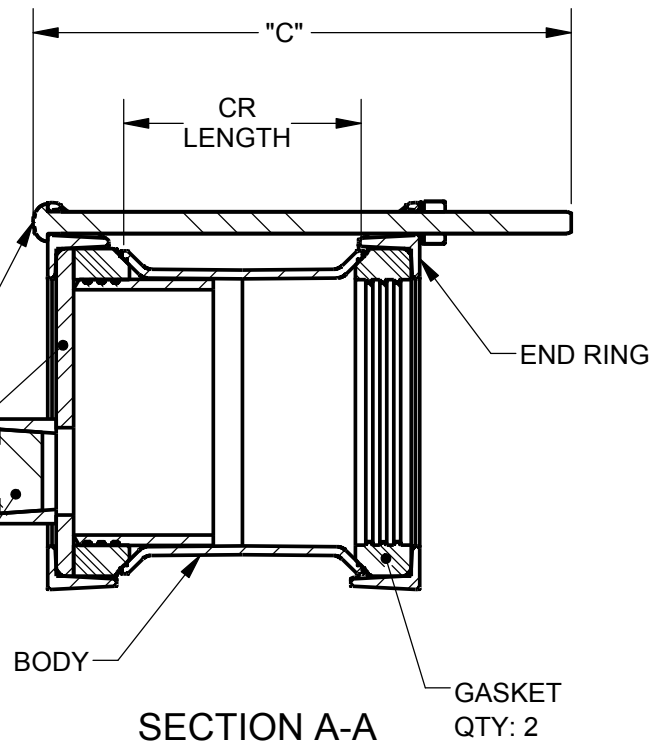

NOTES:

1. ALL MATERIAL DUCTILE IRON UNLESS STATED OTHERWISE.
2. FASTENERS: HSLA PER AWWA C111. STAINLESS STEEL TYPE 304 OR 316 AVAILABLE UPON REQUEST.
3. GASKETS: EPDM, COMPOUNDED FOR WATER & SEWER SERVICE. NBR AVAILABLE ON REQUEST.
4. WORKING PRESSURE IS DEPENDENT ON BURNOUT THICKNESS, 150 PSI & 260 PSI WORKING PRESSURES AVAILABLE.
5. TEST PRESSURE= 1.5 X "WORKING PRESSURE".
6. SHOP COAT APPLIED FOR CORROSION PROTECTION IN TRANSIT. FUSION BONDED EPOXY AVAILABLE ON REQUEST.

|   |  |                        |            |                       |   |           |                |              |
|---|--|------------------------|------------|-----------------------|---|-----------|----------------|--------------|
| PROPRIETARY NOTICE  | UNLESS OTHERWISE SPECIFIED   | SIGNATURES             | DATE       | ROMAC INDUSTRIES INC. |   |           |                |              |
| THIS DRAWING CONTAINS CONFIDENTIAL PROPRIETARY INFORMATION AND IS THE PROPERTY OF ROMAC IND., INC. IT IS TO BE USED ONLY FOR THE PURPOSE FOR WHICH IT WAS SUBMITTED AND SHALL NOT HAVE ITS INFORMATION DISCLOSED OR REPRODUCED IN WHOLE OR IN PART FOR ANY PURPOSE WITHOUT PRIOR WRITTEN PERMISSION OF ROMAC IND., INC. | DIMENSIONS ARE IN INCHES<br>TOLERANCES ARE ON:<br>1 PL DECIMALS ± 0.060<br>2 PL DECIMALS ± 0.030<br>3 PL DECIMALS ± 0.010<br>ANGLES ± 1°<br>FRACTIONS ± 1/64 | DRAWN<br>Peter Nielsen | 01/14/2015 |                       | TITLE<br>ECXR501 - 4" THRU 12" - WITH REMOVABLE END CAP |           |                |              |
|   |  | APPROVED<br>Sam Hill   | 3/27/2019  |                       | DWG. NO.<br>CAD-017539                                  | SIZE<br>A | REV. NO.<br>R1 | SCALE<br>1:8 |

MODEL NAME: ECXR501 - 4 INCH - 12 INCH - TABLE DRAWING MODEL

MODEL CAD #: CAD-017526

LEGACY DRAWING #:

AUTHOR: Peter Nielsen

CONFIGURATION NAME: Default

DRAWING FILE NAME: ECXR501 - 4 INCH - 12 INCH - CUSTOMER DRAWING