

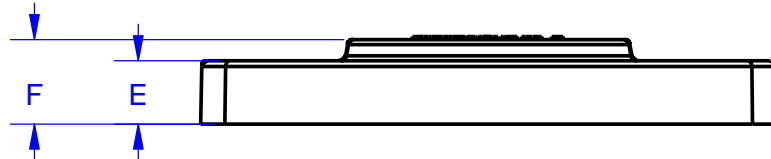

| REVISIONS | | | |
|-----------|-----------------|--------|--------|
| REV. | DESCRIPTION | DATE | EDITOR |
| R0 | INITIAL RELEASE | 7/7/14 | SH |

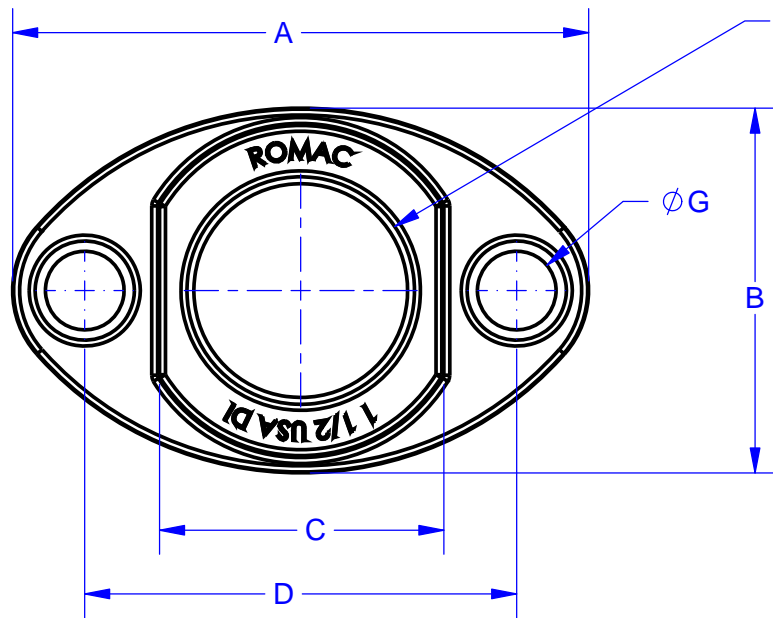

NOTE:

- MATERIAL: ASTM A536 GR. 65-45-12**
- COATING: BLACK SHOPCOAT**

| DIMENSIONS | | | | | | | | | |
|------------|-----------|------|------|------|------|------|------|------|-----------|
| SIZE | THRD SIZE | A | B | C | D | E | F | G | BOLT SIZE |
| 1 1/2 | 1 1/2 NPT | 5.50 | 3.80 | 2.40 | 4.00 | 0.66 | 0.84 | 0.72 | 5/8" |
| 2 | 2 NPT | 6.00 | 3.80 | 3.00 | 4.50 | 0.66 | 0.88 | 0.82 | 3/4" |

| | | | | | | | | | | | | | |
|---|--|--|--|-------------------|--|-------------|--|--|--|-----------|----------------|--------------|-----------------|
| PROPRIETARY NOTICE | | UNLESS OTHERWISE SPECIFIED | | SIGNATURES | | DATE | | ROMAC INDUSTRIES INC. | | | | | |
| THIS DRAWING CONTAINS CONFIDENTIAL PROPRIETARY INFORMATION AND IS THE PROPERTY OF ROMAC IND., INC. IT IS TO BE USED ONLY FOR THE PURPOSE FOR WHICH IT WAS SUBMITTED AND SHALL NOT HAVE ITS INFORMATION DISCLOSED OR REPRODUCED IN WHOLE OR IN PART FOR ANY PURPOSE WITHOUT PRIOR WRITTEN PERMISSION OF ROMAC IND., INC. | | DIMENSIONS ARE IN INCHES TOLERANCES ARE ON: 1 PL DECIMALS ± 0.060 2 PL DECIMALS ± 0.030 3 PL DECIMALS ± 0.010 ANGLES ± 1° FRACTIONS ± 1/64 | | DRAWN Sam Hill | | 07/07/2014 | |  TITLE METER COMPANION FLANGE, 1 1/2" AND 2" | | | | | |
| | | | | APPROVED | | | | | | | | | |
| MODEL NAME: METER FLANGE | | | | MODEL CAD #: | | | | DWG. NO. CAD-012826 | | SIZE A | REV. NO. R* | SCALE 1:2 | SHEET 1 OF 1 |

MODEL NAME: METER FLANGE
CONFIGURATION NAME:2

MODEL CAD #:

LEGACY DRAWING #:

DRAWING FILE NAME: CAD-012825 METER FLANGE

AUTHOR: