

PART NO.	QTY.	NAME	MATERIAL
1	2	CASING	DUCTILE IRON
2	2	BALL	DUCTILE IRON
3	1	SLEEVE	DUCTILE IRON
4	2	LOCKRING	TYPE 403 SS
5	2	RUBBER RING	SBR OR EPDM
6	2	RUBBER RING	SBR OR EPDM
7	2	CASING COVER	CR

DIMENSIONS															
SIZE	D	H OFFSET	L	ANGLE A	EXPANSION/CONTRACTION	OD	BC	ID	T	T2	FLANGE BOLT HOLES		PRESSURE (PSI)		WGT., LBS.
											QTY	DIA	WRK	TEST	
30"	43.3	7.9	79.5	±15.0°	+7.9/ -7.9	38.8	36.00	30.0	1.00	0.60	28	1.38	232	290	4,200
		11.8	90.2												4,400
		15.7	104.9												4,600
		19.7	119.6												4,900
36"	49.2	7.9	79.7	±15.0°	+8.6/ -8.6	46.0	42.75	36.0	1.10	0.63	32	1.63	232	290	6,200
		11.8	94.9												6,400
		15.7	110.1												6,600
		19.7	125.3												6,800
42"	53.3	7.9	82.0	±15.0°	+8.6/ -8.6	53.0	49.50	42.0	1.25	0.67	36	1.63	145	217	7,300
		11.8	97.2												7,700
		15.7	112.4												7,900
		19.7	127.6												8,200

REVISIONS			
REV.	DESCRIPTION	DATE	APPROVED
0	INITIAL RELEASE	6/9/2004	DH EATON
1	PT. NO. 7 WAS SBR, EXPANSION/CONTRACTION OF 36" AND 42" WAS ±7.9"	3/9/2005	DH EATON
2	ADDED EPDM AS OPTION TO PART 5 & 6. CHANGED SHEET FORMAT TO NEW TEMPLATE. ADDED PRESSURE RATING TO TABLE.	2/20/2009	NIELS THOGERSEN
3	NAME WAS FLEXIJUNT	6/30/2011	NIELS THOGERSEN
4	ADDED OD DIMENSION. "D" DIMENSION MOVED TO CORRECT LOCATION.	8/7/2017	C. NICHOLS

**NOTE:**  
 1. FUSION BONDED EPOXY APPLIED TO ALL DUCTILE IRON COMPONENTS.  
 2. FLANGE COMPATIBLE WITH ANSI B16.1 CLS 125 & B16.5 CLASS 150 DRILLING.

**PROPRIETARY NOTICE**  
 THIS DRAWING CONTAINS CONFIDENTIAL PROPRIETARY INFORMATION AND IS THE PROPERTY OF ROMAC IND., INC. IT IS TO BE USED ONLY FOR THE PURPOSE FOR WHICH IS WAS SUBMITTED AND SHALL NOT HAVE ITS INFORMATION DISCLOSED OR REPRODUCED IN WHOLE OR IN PART FOR ANY PURPOSE WITHOUT PRIOR WRITTEN PERMISSION OF ROMAC IND., INC.

**UNLESS OTHERWISE SPECIFIED**  
 DIMENSIONS ARE IN INCHES  
 TOLERANCES ARE ON:  
 1 PL DECIMALS ± .020  
 2 PL DECIMALS ± .010  
 3 PL DECIMALS ± .005  
 ANGLES ± 1°  
 FRACTIONS ± 1/64

**SIGNATURES**  
 DRAWN  
 N. THOGERSEN III 6/30/11  
 CHECKED  
 APPROVAL ORGANIZATIONS  
 ENGINEERING

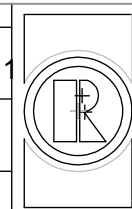

**ROMAC INDUSTRIES INC., BOTHELL, WA**  
 TITLE  
**FJ-RESTRAINT, 30", 36", & 42" DOUBLE BALL, FLANGED**  
 DWG. NO. B2294-B    SIZE B    REV. NO. 4    SCALE NTS    SHEET 1 OF 1