

SIZE	PIPE OD RANGE	BODY OD	LENGTH	HEIGHT	MAX PRESSURE [PSI]	MAX DEFLECTION [DEGREES]	APPX. WEIGHT [LBS]
		A [A]	B [A]	C [A]			
4	4.50-4.90	8.1	7.4	9.8	350	4	21
6	6.60-7.00	10.4	7.9	12.0	350	4	30
8	8.60-9.10	13.4	9.7	15.1	350	4	52
10	10.75-11.20	15.5	9.9	17.1	350	4	63
12	12.75-13.30	17.5	10.3	19.2	350	4	78

REVISIONS			
REV.	DESCRIPTION	DATE	EDITOR
R3	A	8/2/21	CMB
	DIMENSIONS UPDATED		

FOR CUSTOMER USE

BODY, NSF 61 FUSION BONDED EPOXY

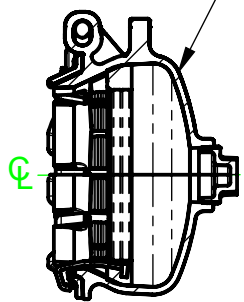

SECTION A-A

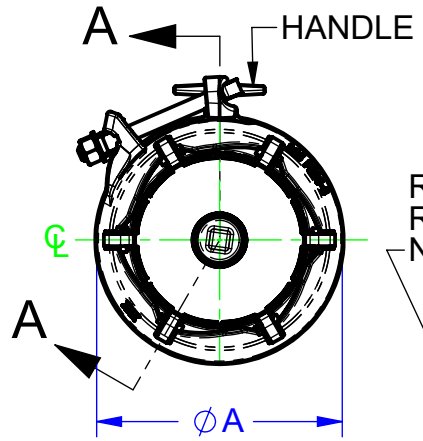

3 1-1/16 HEX NUT HSLA (R-BLUE)

3 WASHER 304 SS

4 BOLT GUIDE, (XYLAN 1212)

3 T-BOLT, 5/8-11 HSLA (R-BLUE)

RAMP RUNNER, REINFORCED NYLON 66

GRIPPERS, (XYLAN 1424)

DRAW HOOK, 304L SS

2 INCH, IP PLUG, MALLEABLE IRON

END RING, (BLACK POLYESTER)

2 GASKET

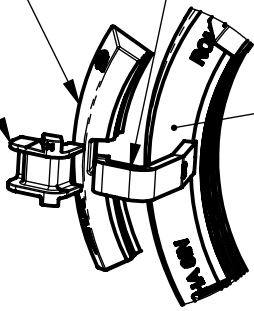

DETAIL B SCALE 1 : 3

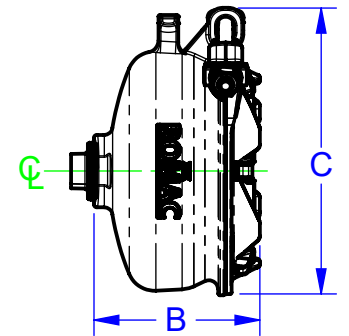

NOTES:

1. ALL MATERIALS ASTM A536 GRADE 65-45-12 DUCTILE IRON UNLESS OTHERWISE SPECIFIED
2. GASKET MATERIAL: NSF 61 SBR PER ASTM D2000 OR NSF 61 NBR AVAILABLE UPON REQUEST
3. FASTENER MATERIAL: HSLA, R-BLUE COATED NUT AND BOLT. WASHER IS 304 SS
4. BOLT GUIDE COMES STANDARD WITH BLACK XYLAN 1212. BLACK E-COAT AVAILABLE UPON REQUEST.
5. MINIMUM INSERTION PER INSTALLATION INSTRUCTIONS

<p>PROPRIETARY NOTICE</p> <p>THIS DRAWING CONTAINS CONFIDENTIAL PROPRIETARY INFORMATION AND IS THE PROPERTY OF ROMAC IND., INC. IT IS TO BE USED ONLY FOR THE PURPOSE FOR WHICH IT WAS SUBMITTED AND SHALL NOT HAVE ITS INFORMATION DISCLOSED OR REPRODUCED IN WHOLE OR IN PART FOR ANY PURPOSE WITHOUT PRIOR WRITTEN PERMISSION OF ROMAC IND., INC.</p>		<p>UNLESS OTHERWISE SPECIFIED</p> <ul style="list-style-type: none"> DIMENSIONS ARE IN INCHES DRAWING NOT PERFECTLY TO SCALE 		<p>SIGNATURES</p> <p>DRAWN Caitlin Boone</p> <p>APPROVED James Protzeller</p>		<p>DATE</p> <p>8/2/2021</p> <p>8/6/2021</p>		<p>ROMAC INDUSTRIES INC.</p> <p>TITLE ALPHA END CAP, 4-12 INCH, STANDARD</p>	
<p>MODEL NAME: ALPHA, END CAP, ASSEMBLY, 6 INCH MODEL CAD #: CAD-045543</p>		<p>CONFIGURATION NAME: EXPLODED VIEW</p>		<p>THIRD ANGLE PROJECTION</p>		<p>LEGACY DRAWING #: DRAWING FILE NAME: ALPHA, END CAP, ASSEMBLY, 4-12 INCH, STD</p>		<p>DWG. NO. CAD-045804</p> <p>SIZE A</p> <p>REV. NO. R3</p> <p>SCALE 1:8</p> <p>SHEET 1 OF 1</p> <p>AUTHOR: Tyler Matthews</p>	

RELEASED