

DISMANTLING JOINTS DJ400 •

DJ400

Sizes from 3" - 72"
Larger sizes available upon request.

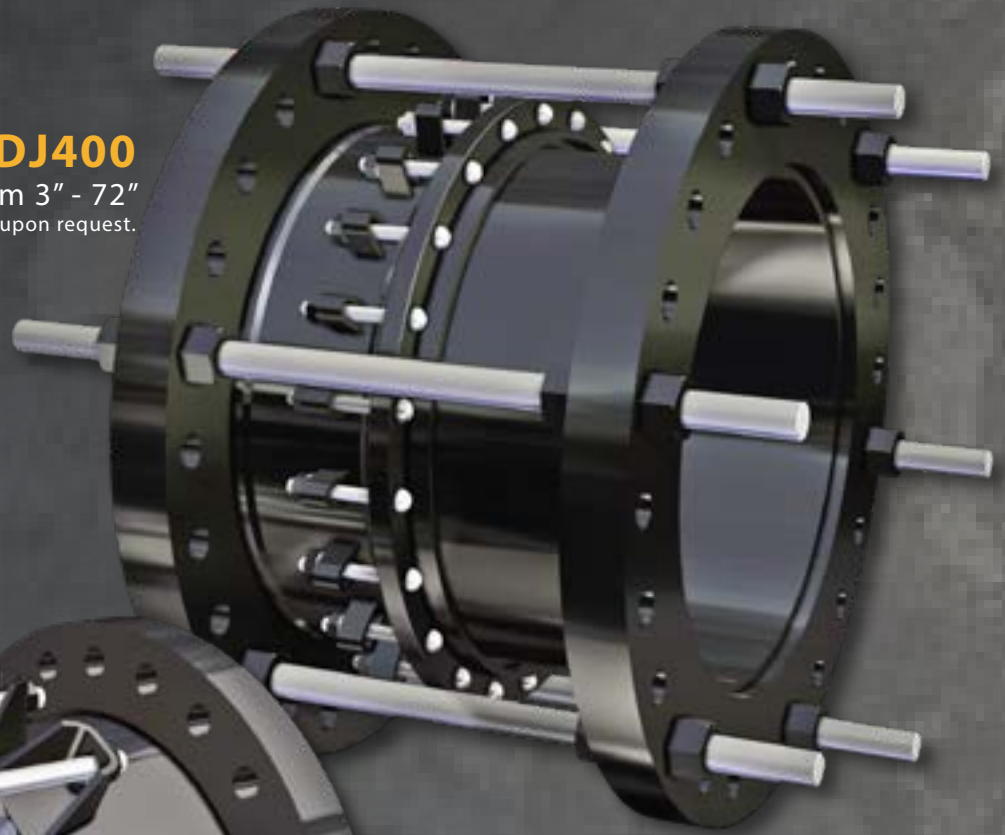

DJ405

3" - 24" sizes

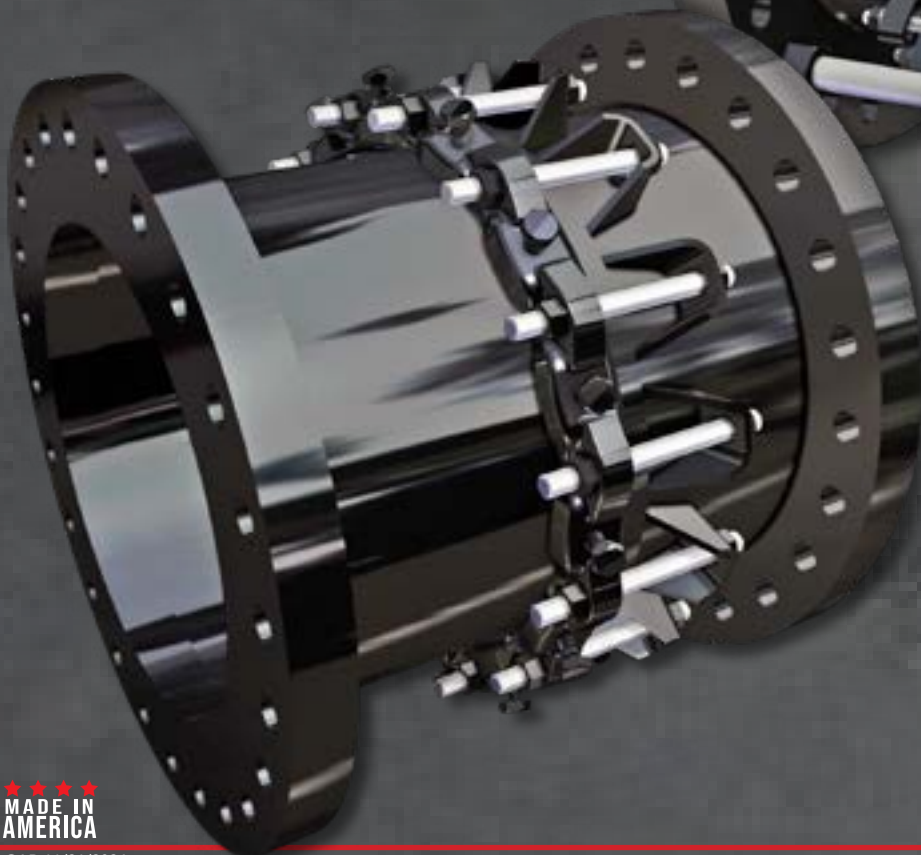

DJ400

- For pipe sizes 3" - 72". Larger sizes available upon request.
- Ideally suited for installation adjacent to valves, meters, pumps, outlets and other fittings.
- Romac Dismantling Joints are available for quick delivery in standard and custom flanged configurations.
- For use on ductile iron, steel, plastic and other types of pipe.
- Manufactured in the U.S.A. 



NSF61/372 Certified upon request.

Romac's DJ400 and DJ405 dismantling joints are telescoping flanged fittings which can be lengthened and shortened, allowing access to valves, pumps and other fittings.



- The DJ400 Spool can be retracted to allow access to valves, pumps and other fittings.



- The length of the DJ400 is adjustable to accommodate different size equipment.



The Romac DJ400 combines a flanged spool piece with restraint tie-rods in one easy-to-use assembly.

DJ405

- For pipe sizes 3" - 24".
- Up to five inches of travel.
- Quick, simple installation.
- Perfect for use in line with pumps, meters, valves and other fittings.
- Allows deflection.
- For use on ductile iron, steel, plastic and other types of pipe.
- Manufactured in the U.S.A. 

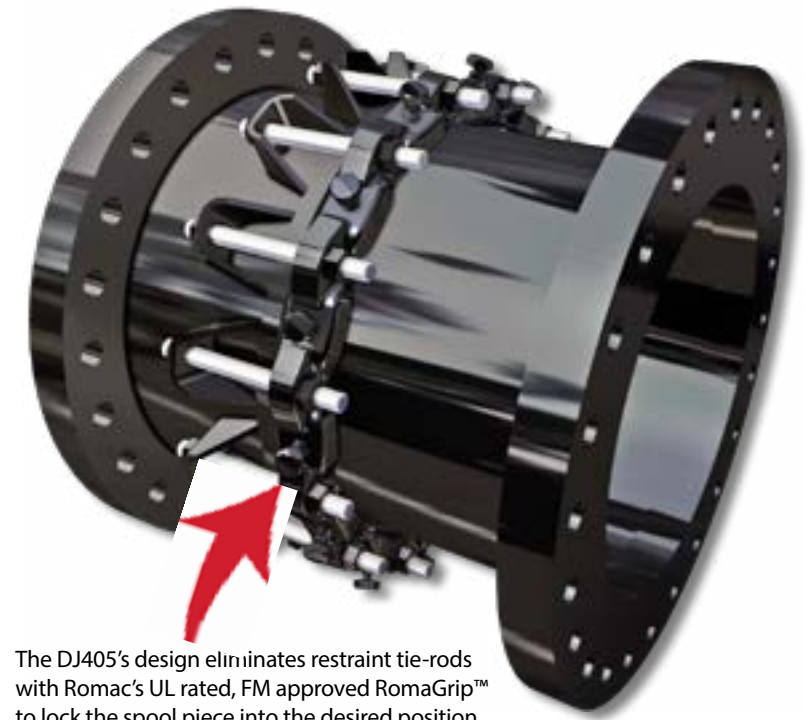

The DJ405's design eliminates restraint tie-rods with Romac's UL rated, FM approved RomaGrip™ to lock the spool piece into the desired position.

NSF61/372 Certified upon request.

Following installation of a Romac dismantling joint, our customer enjoys a fully restrained connection allowing a desirable assembly and disassembly tolerance within the system.



- The DJ405 Spool can be retracted to allow access to valves, pumps and other fittings.



- The length of the DJ405 is adjustable to accommodate different size equipment.

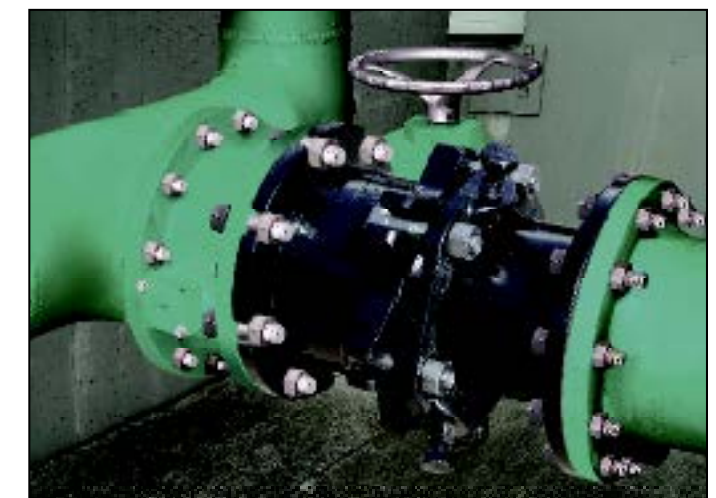

DJ405 is ideal for use in line with pumps, meters and valves.

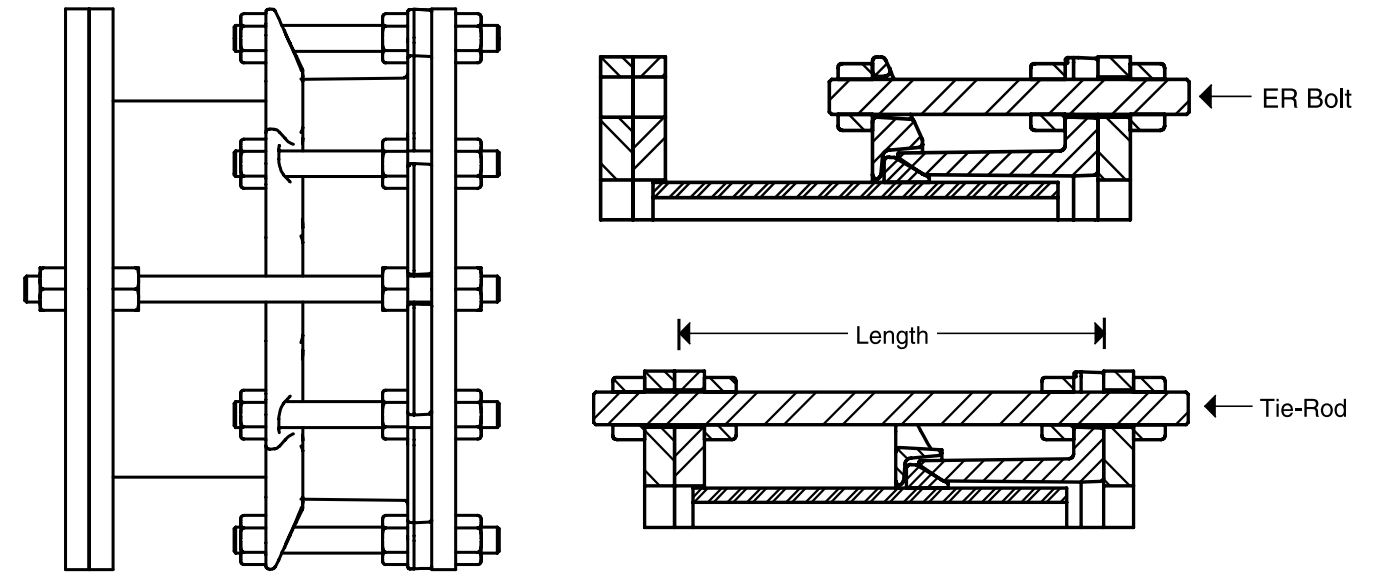
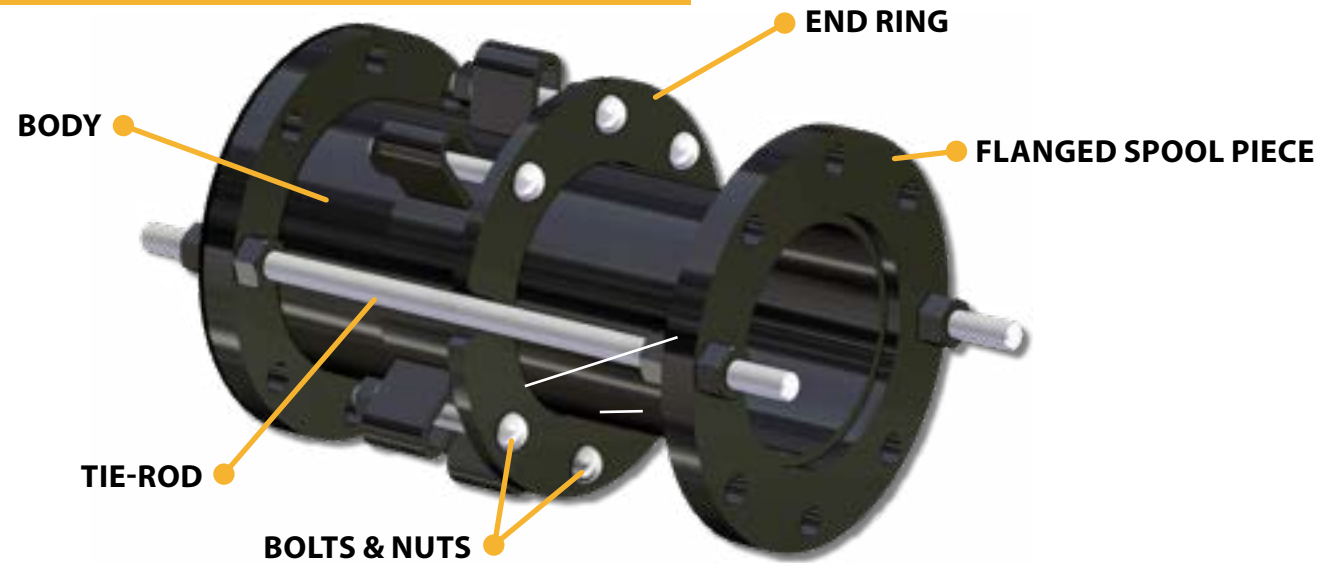

MATERIAL SPECIFICATIONS

FLANGE SPOOL (3-12 inch): AWWA Class D Steel Ring Flange, compatible with ANSI Class 125 and 150 bolt circles. Pipe is STD Weight Class per ASTM A53.

FLANGE SPOOL (14-72 inch): AWWA Class D Steel Ring Flange, compatible with ANSI Class 125 and 150 bolt circles. Pipe is ASTM A36 plate 1% cold expanded to size.

END RING & BODY (3-12 inch): The end ring and body are made from ASTM A536 65-45-12 Ductile Iron.

END RING & BODY (14-72 inch): The end ring and body are made from ASTM A36 steel.

GASKETS: NBR Gaskets are made from rubber compounded for water and sewer service in accordance with ASTM D 2000 MBA810Z. Other compounds are available for petroleum, chemical, or high temperature service.

BOLTS & NUTS: ASTM A588 HSLA bolt material. Stainless Steel, Types 304 or 316 is optional.

TIE-RODS: High tensile steel per ASTM A193 grade B7. Stainless steel, type 304 or 316 is optional.

COATING: Fusion bonded epoxy.

PRESSURE (3-12 inch): When properly installed on a pipe that is within the coupling manufacturer's tolerances, Romac style DJ400 Dismantling Joint can work at pressures up to the maximum rating of the flange. AWWA Class D flanges are rated for 175 psig. Higher working pressures can be accommodated. Consult your representative.

PRESSURE (14-72 inch): When properly installed on a pipe that is within the coupling manufacturer's tolerances, Romac style DJ400 can work at pressures up to the maximum rating of the flange. AWWA Class D flanges are rated for 150 psi in 14" and larger sizes. Higher working pressures can be accommodated. Consult your representative.

ASSEMBLY TOLERANCE (3-12 inch): Two inches flange face to flange face. For more length, contact Romac Engineering.

ASSEMBLY TOLERANCE (14-72 inch): Three inches flange face to flange face. For more length, contact Romac Engineering.

DJ400 SIZES 3" - 72" LARGER SIZES AVAILABLE UPON REQUEST.

NOM SIZE	DIMENSIONS					ER BOLTS		TIE RODS				FLANGED SPOOL			APPROX WEIGHT LBS
	FLANGE OD	FCA FLANGE THK	LENGTH			QTY	SIZE	SIZE (UNC)	LENGTH	QTY	ALLOY	SS	OD	PIPE THK	
NOM.	MIN.	MAX.													
3	7.50	0.60	8.00	7.00	9.00	2	5/8 - 11	5/8 - 11	13.50	2	2	3.50	0.22	0.63	31
4	9.00	0.60	8.00	7.00	9.00	4	5/8 - 11	5/8 - 11	13.50	2	2	4.50	0.24	0.63	36
6	11.00	0.63	8.38	7.38	9.38	4	3/4 - 10	3/4 - 10	15.00	2	2	6.63	0.28	0.69	55
8	13.50	0.63	8.38	7.38	9.38	4	3/4 - 10	3/4 - 10	15.00	2	2	8.63	0.32	0.69	72
10	16.00	1.24	10.50	9.50	11.50	6	5/8 - 11 X 7/8 - 9	7/8 - 9	17.75	2	2	10.75	0.37	0.69	108
12	19.00	1.25	10.50	9.50	11.50	6	7/8 - 9	7/8 - 9	17.75	2	2	12.75	0.38	0.81	134
14	21.00	0.94	13.50	12.00	15.00	8	5/8 - 11	1 - 8	22.00	2	2	14.00	0.25	0.94	152
16	23.50	1.00	13.50	12.00	15.00	10	5/8 - 11	1 - 8	22.00	2	2	16.00	0.25	1.00	185
18	25.00	1.06	13.75	12.25	15.25	10	5/8 - 11	1 1/8 - 7	23.25	2	4	18.00	0.25	1.06	201
20	27.50	1.13	13.75	12.25	15.25	12	5/8 - 11	1 1/8 - 7	23.25	2	4	20.00	0.25	1.13	239
24	32.00	1.25	14.25	12.75	15.75	14	5/8 - 11	1 1/4 - 7	25.50	2	4	24.00	0.25	1.25	339
30	38.75	1.38	14.75	13.25	16.25	16	5/8 - 11	1 1/4 - 7	25.50	4	6	30.00	0.38	1.38	506
36	46.00	1.63	15.75	14.25	17.25	18	5/8 - 11	1 1/2 - 6	27.50	4	6	36.00	0.38	1.63	757
42	53.00	1.75	16.50	15.00	18.00	20	5/8 - 11	1 1/2 - 6	29.25	4	6	42.00	0.38	1.75	1005
48	59.50	1.88	16.75	15.25	18.25	22	5/8 - 11	1 1/2 - 6	29.25	6	8	48.00	0.38	1.88	1260
54	66.25	2.13	17.75	16.25	19.25	24	5/8 - 11	1 3/4 - 5	31.75	6	8	54.00	0.38	2.13	1657
60	73.00	2.25	18.00	16.50	19.50	28	5/8 - 11	1 3/4 - 5	31.75	6	10	60.00	0.38	2.25	1993
72	86.50	2.63	18.75	17.25	20.25	32	5/8 - 11	1 3/4 - 5	33.50	10	14	72.00	0.38	2.63	2960

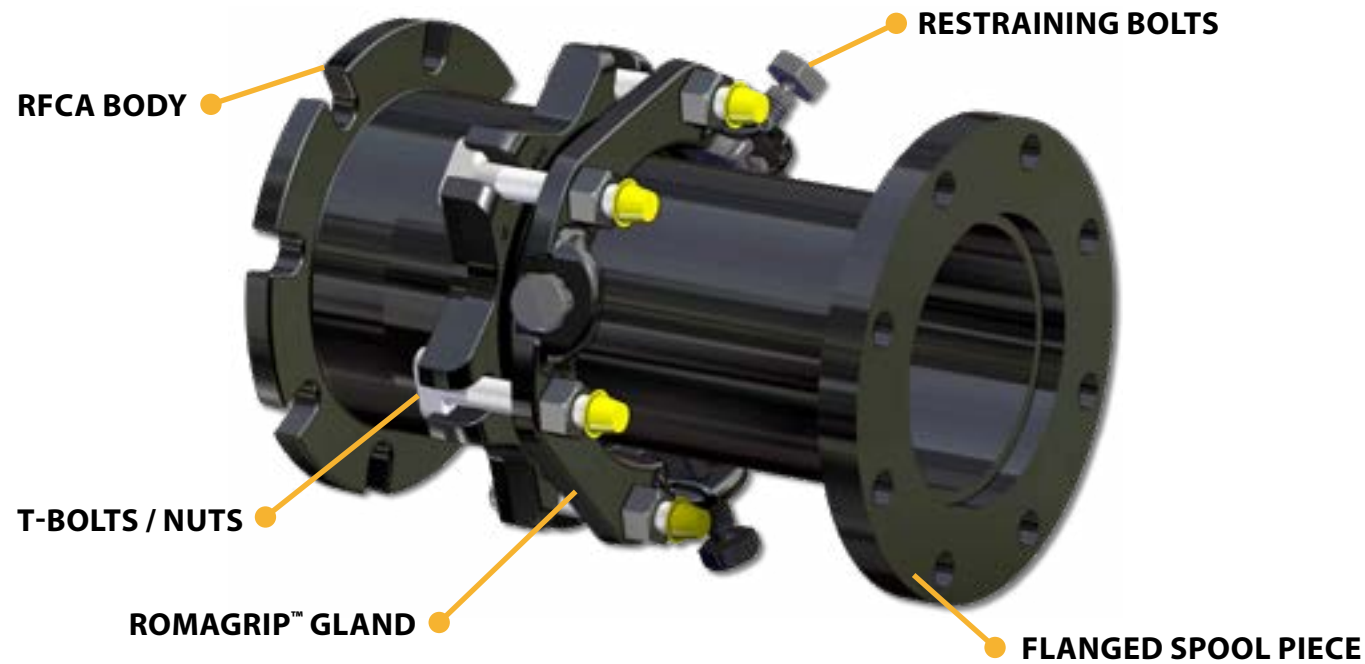

Restraining Bolts

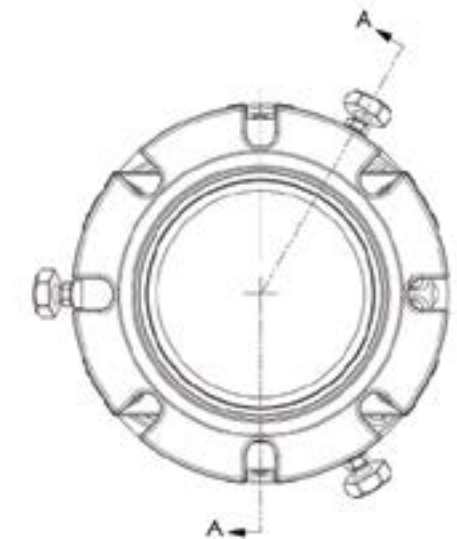
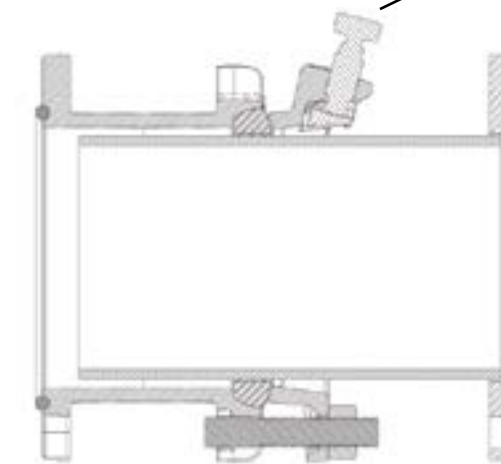
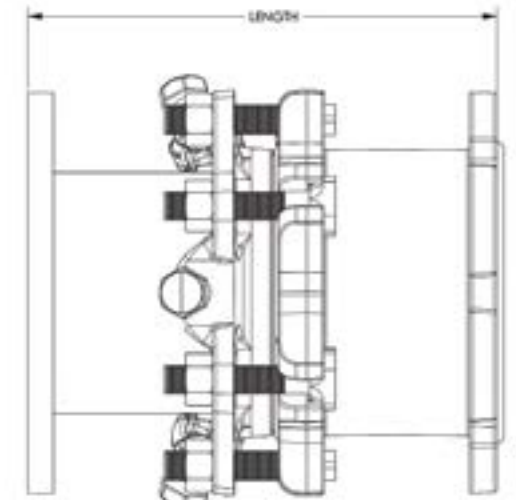

MATERIAL SPECIFICATIONS

FLANGE SPOOL: AWWA Class D Flange compatible with ANSI class 125 and 150 bolt circles. For 3" - 12" sizes, pipe is Sch 40 ASTM A53. For 14" - 24" pipe material is ASTM A36.

BODY: ASTM A536 ductile (nodular) iron meeting or exceeding Grade 65-45-12, with ANSI Class 125 and 150 bolt circles.

GASKETS: Compounded for water and sewer service in accordance with ASTM D 2000 (RFCA gasket is o-ring style). Other compounds available for petroleum, chemical, or high temperature service.

GLAND: Romac RomaGrip™ coated with Romabond Polyester.

RESTRAINING BOLTS: 7/8 - 9 roll thread, Ductile (nodular) iron, meeting or exceeding ASTM A 536. ASTM A588 HSLA bolt material. Stainless Steel, Types 304 or 316 is optional.

RESTRAINING LUGS: Ductile (nodular) iron, meeting or exceeding ASTM A 536. Heat treated using a proprietary process.

LUG LOCATORS: Polyurethane, a thermal plastic.

T-BOLTS AND NUTS: High strength low alloy steel T-head bolt. National coarse rolled thread and heavy hex nut. Steel meets AWWA C111 composition specifications. Stainless steel bolts and nuts available on request.

COATING: Fusion bonded epoxy.

WORKING PRESSURE		
NOMINAL SIZE	CLASS D* FLANGE	CLASS E* FLANGE
3" - 12"	175	275
14" - 24"	150	275

*Standard flange on DJ405 is AWWA Class D. Class E flanges are available as an option.

ASSEMBLY TOLERANCE		
NOMINAL SIZE	LENGTH TOLERANCE	
	+ (inches)	TOTAL (inches)
3"	1.50	3.0
4"	1.75	3.5
6" - 8"	2.00	4.0
10" - 12"	2.25	4.5
14" - 24"	2.50	5.0

DJ405 SIZES 3" - 24"

NOM SIZE	DIMENSIONS					ALLOWABLE DEFLECTION (degrees)	T-BOLTS			FLANGED SPOOL			TOTAL WEIGHT (LBS)
	FLANGE OD	FOA FLANGE THK	LENGTH				QTY	SIZE	LENGTH	PIPE OD	PIPE THK	FLG THK	
3	7.5	0.76	11.50	10.00	13.00	2.0	4	5/8"	3.75	3.50	0.22	0.63	33
4	9.0	0.76	12.75	11.00	14.50	3.5	4	3/4"	4.25	4.50	0.24	0.63	46
6	11.0	0.76	13.50	11.50	15.50	3.5	6	3/4"	4.25	6.53	0.25	0.69	66
8	13.5	0.75	13.50	11.50	15.50	3.3	6	3/4"	4.25	9.53	0.32	0.69	94
10	16.0	0.75	14.75	12.50	17.00	3.0	6	3/4"	4.25	10.75	0.37	0.69	143
12	18.0	0.81	14.75	12.50	17.00	3.0	8	3/4"	4.25	12.75	0.38	0.81	193
14	21.0	1.38	19.25	16.75	21.75	2.0	10	3/4"	4.50	16.30	0.38	0.94	297
16	23.5	1.44	19.25	16.75	21.75	2.0	12	3/4"	4.50	17.40	0.38	1.00	362
18	25.0	1.46	20.25	17.75	22.75	1.5	12	3/4"	4.50	18.50	0.38	1.06	390
20	27.5	1.47	20.25	17.75	22.75	1.5	14	3/4"	4.50	21.60	0.38	1.13	487
24	32.0	1.50	21.25	18.75	23.75	1.5	16	3/4"	5.00	25.60	0.38	1.25	588

ROMAC INDUSTRIES, INC.

Repair Clamps • Couplings • Expansion Joints • Pipe Restraint • Service Saddles
Tapping Sleeves • Tapping Machines • Valve Insertion • Waterworks Tools

1.800.426.9341 • www.romac.com

