

INSTALLATION INSTRUCTIONS

Read installation instructions first before installing. Check parts to ensure that no damage has occurred during transit and that no parts are missing. Also check the diameter of the pipe and the range marked on the coupling to ensure you have the proper size.

Style IC400 Fabricated Steel Coupling with insulating boot (12" - 72")

PIPE ENDS

Step 1 • Pipe End Preparation: The pipe ends shall be free from indentations, projections or roll marks for a distance 2" greater than the length of the coupling. The pipe ends shall conform to the diameter and roundness tolerances stated in the table below.

NOMINAL PIPE SIZE	OD TOLERANCE		ROUNDNESS
	+	-	MIN/MAX ¹
1/2" TO ≤ 16"	0.06"	0.06"	1/8"
> 16" TO ≤ 24"	0.08"	0.08"	1/8"
> 24" TO ≤ 42"	0.10"	0.10"	1/8"
> 42" TO < 60"	0.12"	0.06"	1/8"

¹ Out of roundness conditions are required to be correctable so that the difference between the minimum and maximum diameters is not greater than this dimension.

Step 2 Clean each pipe end for a distance of 2" greater than length of the insulating boot. Check area where gaskets will seat to make sure there are no dents, projections, gouges, etc. that will interfere with the gasket seal. Welds must be ground flush.

Step 3 Place a reference mark on pipe an equal distance from each pipe end for centering coupling over the pipe ends.

Step 4 Place one end ring on each pipe end.

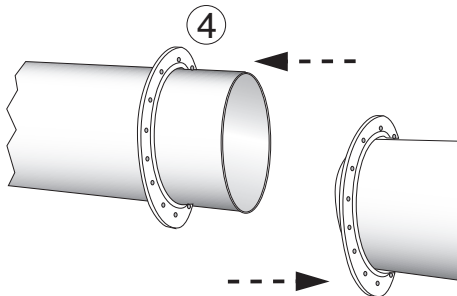

Step 5 Place insulating boot on pipe.

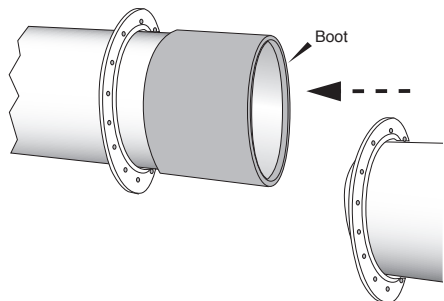

Step 6 Clean and lubricate gaskets. Place the gasket without the tail on the insulating boot. Place the gasket with the tail on the opposite pipe, with beveled edge toward the pipe ends. If the coupling has two boots, then both will not have a tail, and can go on either side.

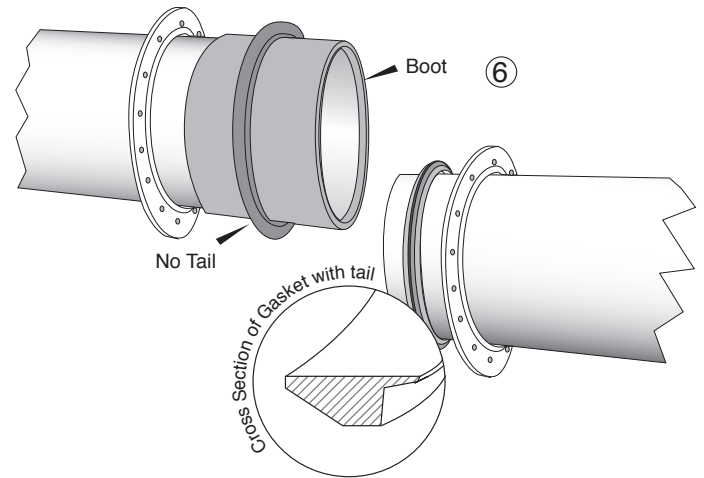

Step 7 Slide center ring onto pipe end.

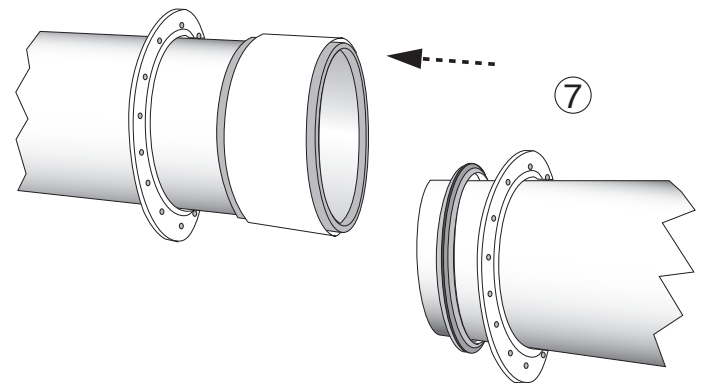

Installation Instructions continued on back

Style IC400 (continued from front)

Step 8 Bring the other pipe end into position. Maintain recommended gap between pipe ends.

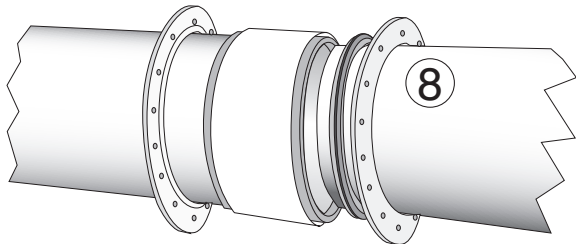

RECOMMENDED GAP BETWEEN PIPE ENDS

Center Ring Length	Straight-Run Pipe*	Deflected Joints**	Maximum Permissible In-Service Centerline Gap*
5"	0.5"	1"	2"
7"	1"	1.5"	3"
10"	1"	2.25"	4.5"

*Recommended gap between pipe ends that is not expected or able to deflect greater than 25% of stated deflection values. See Romac Catalog Page 2-25, "400 Coupling Options."

**Recommended gap between pipe ends to achieve maximum deflection. The maximum allowable deflection should only be used when the pipes will not move in service.

Step 9 Center ring should be positioned such that pipe entrance is equal. Slide gaskets into position with the beveled edge engaging the flared end of center ring.

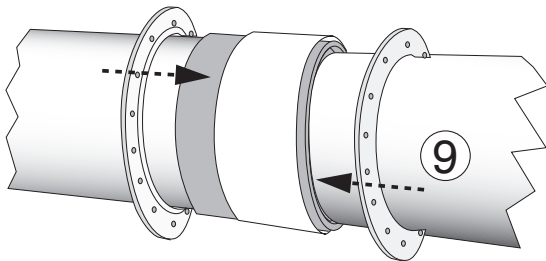

Step 10 Slide the end rings into position against the gaskets.

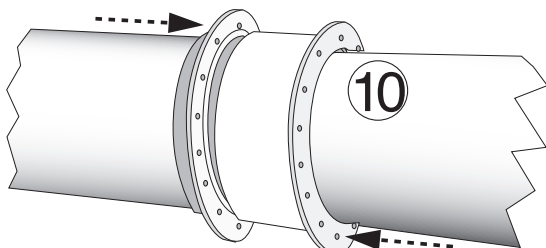

Step 11 Check coupling for proper positioning over pipe ends using reference marks. (See Step 2).

Step 12 Insert bolts through the end rings, and thread nuts finger tight.

Tighten bolts evenly, alternating to diametrically opposite positions to bring bolts to the recommended tightness. (60-70 ft-lbs. for 5/8" bolts and 85-95 ft-lbs. for 3/4" bolts).

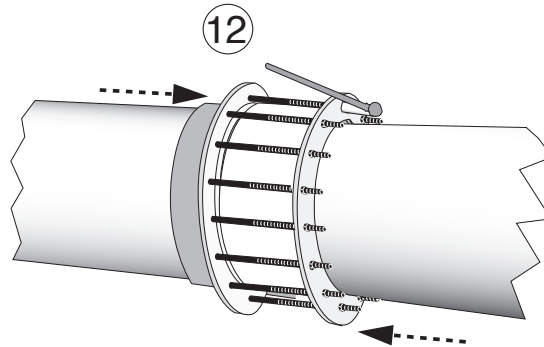

Wait 10 minutes and retighten to account for settling of the gasket.



Step 13 • Confirm proper installation by pressurizing the line and checking for leaks. Pressure test up to 1.5X working pressure.

Note: Flexible Couplings do not provide protection against axial force. Suitable anchorage should be provided.



CAUTION: When reinstalling parts with stainless steel hardware there may be a loss in pressure holding ability due to worn or damaged threads during the original installation.



CAUTION: IRC400 couplings with a step in the center ring have the potential for migrating along the pipe; therefore some form of restraint should be used.