

TapMate™ & TapMate XL™ Travel Charts

Travel distances are measured from when the shell cutter makes contact with the pipe.

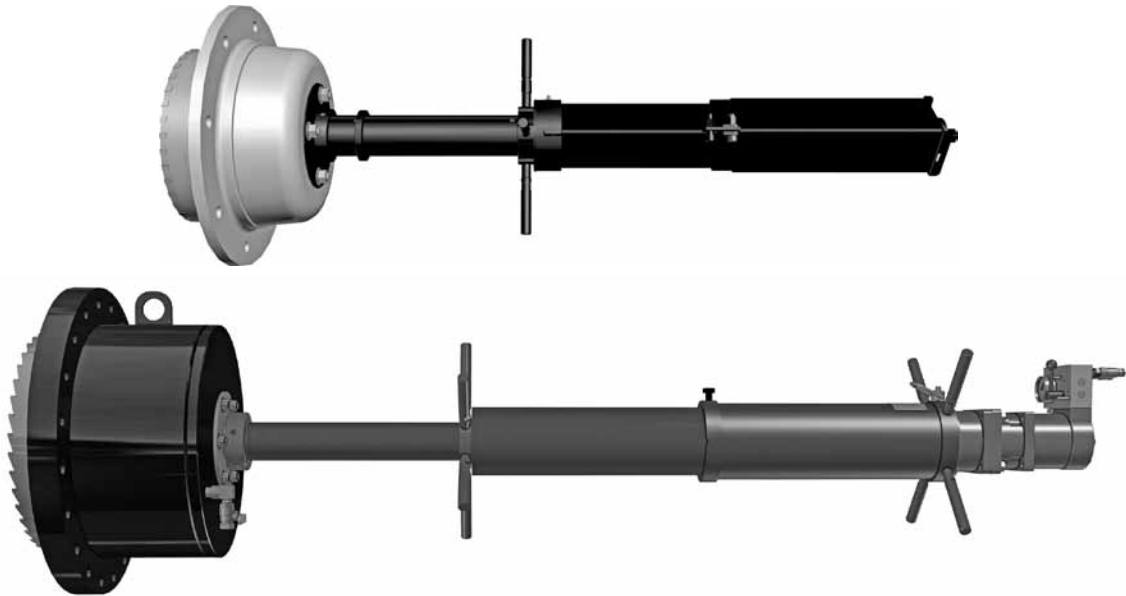

Cast Iron Pipe	page 2
Ductile Iron Pipe	pages 3 - 4
C900 PVC Pipe	page 5
C905 Pipe	pages 6 - 7
C905 (IPS) Pipe.....	page 8
C909	pages 9 - 10
ASTM D2241 - IPS PVC Pipe	pages 11 - 12
ASTM D1785 PVC (Sch. 40, 80 & 120) Pipe	pages 13 - 14
HDPE Pipe	pages 15 - 17
Asbestos Cement (A/C) Pipe.....	page 18

Cast Iron Pipe

Nominal Size		4	6	8	10	12	14	16	18	20	24
PIPE OD	Class 100						15.30	17.40	19.50	21.60	25.80
	Class 150	4.80	6.90	9.05	11.10	13.20	15.65	17.80	19.92	22.06	26.32
	Class 200			9.05	11.10	13.20	15.65	17.80	19.92	22.06	26.32
	Class 250	4.80	6.90	9.05	11.10	13.20	15.65	17.80	19.92	22.06	26.32
WALL THICKNESS	Class 100						0.48	0.52	0.56	0.58	0.64
	Class 150	0.34	0.37	0.42	0.47	0.50	0.55	0.60	0.65	0.68	0.76
	Class 200			0.46	0.52	0.57	0.62	0.68	0.74	0.78	0.88
	Class 250	0.38	0.43	0.50	0.57	0.62	0.69	0.75	0.83	0.88	1.00

***** TRAVEL DISTANCE *****

(DISTANCE IS FROM WHERE CUTTER CONTACTING PIPE OD WALL - NOT THE PILOT)

TAP SIZE 4 (actual size 3-1/2")	Class	100						3/4"	3/4"	3/4"	3/4"	7/8"
		150	1-3/8"	1"	7/8"	7/8"	7/8"	7/8"	7/8"	7/8"	1"	1"
		200			7/8"	7/8"	7/8"	7/8"	7/8"	1"	1"	1"
		250	1-1/2"	1"	1"	1"	1"	1"	1"	1"	1-1/8"	1-1/8"
TAP SIZE 6 (actual size 5-1/2")	Class	100						1-1/8"	1"	1"	1"	1"
		150	2-1/8"	1-1/2"	1-3/8"	1-1/4"	1-1/8"	1-1/8"	1-1/8"	1-1/8"	1-1/8"	1-1/8"
		200		1-5/8"	1-3/8"	1-1/4"	1-1/4"	1-1/4"	1-1/4"	1-1/4"	1-1/4"	1-1/4"
		250	2-1/4"	1-5/8"	1-1/2"	1-3/8"	1-1/4"	1-3/8"	1-3/8"	1-3/8"	1-3/8"	1-3/8"
TAP SIZE 8 (actual size 7-1/2")	Class	100						1-5/8"	1-1/2"	1-3/8"	1-3/8"	1-1/4"
		150	2-7/8"	2-1/8"	1-7/8"	1-1/8"	1-1/8"	1-1/8"	1-1/8"	1-1/8"	1-1/8"	1-1/8"
		200	3"	2-1/4"	2"	1-3/4"	1-5/8"	1-5/8"	1-1/2"	1-1/2"	1-1/2"	
		250	3-1/8"	2-3/8"	2"	1-7/8"	1-3/4"	1-3/4"	1-5/8"	1-5/8"	1-5/8"	
TAP SIZE 10 (actual size 9-1/2")	Class	100						2-3/8"	2-1/8"	2"	1-3/4"	1-5/8"
		150	3-3/4"	2-7/8"	2-3/8"	2-1/8"	2"	2"	1-7/8"	1-3/4"	1-3/4"	
		200	4"	3"	2-1/2"	2-1/4"	2-1/8"	2"	2"	1-7/8"	1-7/8"	
		250	4-1/8"	3"	2-1/2"	2-3/8"	2-1/4"	2-1/4"	2-1/8"	2-1/8"	2"	
TAP SIZE 12 (actual size 11-1/2")	Class	100						3-3/8"	3"	2-5/8"	2-3/8"	2-1/8"
		150	4-5/8"	3-3/8"	3-3/8"	3"	2-5/8"	2-1/2"	2-1/4"	2-3/8"	2-3/8"	
		200	4-7/8"	3-1/2"	3-1/2"	3-1/8"	2-3/4"	2-5/8"	2-3/8"	2-3/8"	2-3/8"	
		250	5"	3-5/8"	3-1/8"	3-1/8"	2-7/8"	2-3/4"	2-3/4"	2-1/2"	2-1/2"	
TAP SIZE 14 (actual size 13-1/2")	Class	100						5-1/4"	4-1/8"	3-5/8"	3-1/8"	2-3/4"
		150	5-1/8"	4-1/8"	4-1/8"	3-5/8"	3-1/4"	3-1/4"	2-3/4"	2-3/4"	2-3/4"	
		200	5-3/8"	4-1/4"	4-1/4"	3-3/4"	3-3/8"	3-3/8"	3"	3"	3"	
		250	5-5/8"	4-3/8"	4-3/8"	3-7/8"	3-1/2"	3-1/2"	3-1/2"	3-1/2"	3-1/8"	
TAP SIZE 16 (actual size 15-1/2")	Class	100						6-1/8"	4-7/8"	4-1/4"	4-1/4"	3-1/2"
		150					6"	4-7/8"	4-1/4"	4-1/4"	3-1/2"	
		200					6-1/4"	5"	4-3/8"	4-3/8"	3-5/8"	
		250					6-1/2"	5-1/4"	4-1/2"	4-1/2"	3-7/8"	
TAP SIZE 18 (actual size 17-1/2")	Class	100						7"	5-5/8"	5-5/8"	4-3/8"	
		150					6-7/8"	5-1/2"	5-1/2"	4-3/8"		
		200					7-1/8"	5-3/4"	5-3/4"	4-5/8"		
		250					7-3/8"	6"	6"	4-3/4"		
TAP SIZE 20 (actual size 19-1/2")	Class	100						7-3/4"	5-1/2"	5-1/2"		
		150					7-5/8"	5-1/2"	5-1/2"			
		200					7-7/8"	5-3/4"	5-3/4"			
		250					8-1/4"	6"	6"			
TAP SIZE 24 (actual size 22-1/2")	Class	100						8-1/8"	8"	8"		
		150					8"	8"	8"			
		200					8-1/4"	8-1/4"	8-1/4"			
		250					8-5/8"	8-5/8"	8-5/8"			

NOTE: Tap sizes 14" - 24" apply to TapMate XL only.

Ductile Iron Pipe

Nominal Size		4	6	8	10	12	14	16	18	20	24
PIPE OD		4.80	6.90	9.05	11.10	13.20	15.30	17.40	19.50	21.60	25.80
PIPE ID. SIZE RANGE	Class 50	4.04	6.40	8.51	10.40	12.46	14.45	16.53	18.61	20.69	24.85
	thru Class 56	3.98	6.04	8.15	10.04	12.10	14.09	16.17	18.25	20.33	24.49
***** TRAVEL DISTANCE *****											
(DISTANCE IS FROM WHERE CUTTER CONTACTING PIPE OD WALL - NOT THE PILOT)											
TAP SIZE 4 (actual size 3-1/2")	Class 50	1-3/8"	7/8"	3/4"	5/8"	5/8"	5/8"	5/8"	5/8"	5/8"	5/8"
	thru Class 56	1-5/8"	1-1/8"	1"	7/8"	7/8"	7/8"	7/8"	7/8"	7/8"	7/8"
TAP SIZE 6 (actual size 5-1/2")	Class 50	2"	1-3/8"	1-1/8"	1"	1"	7/8"	7/8"	7/8"	3/4"	
	thru Class 56	2-3/8"	1-5/8"	1-3/8"	1-1/4"	1-1/4"	1-1/8"	1-1/8"	1"	1"	
TAP SIZE 8 (actual size 7-1/2")	Class 50	2-5/8"	2"	1-5/8"	1-1/2"	1-3/8"	1-1/4"	1-1/8"	1-1/8"	1"	
	thru Class 56	3-1/8"	2-1/4"	1-7/8"	1-3/4"	1-5/8"	1-1/2"	1-3/8"	1-1/4"		
TAP SIZE 10 (actual size 9-1/2")	Class 50	3-3/8"	2-5/8"	2-1/4"	2"	1-3/4"	1-5/8"	1-3/8"			
	thru Class 56	4"	2-7/8"	2-1/2"	2-1/4"	2"	1-7/8"	1-5/8"			
TAP SIZE 12 (actual size 11-1/2")	Class 50	4-1/8"	3-1/4"	2-3/4"	2-1/2"	2-1/4"	1-7/8"				
	thru Class 56	4-3/4"	3-5/8"	3"	2-3/4"	2-1/2"	2-1/8"				
TAP SIZE 14 (actual size 13-1/2")	Class 50	5"	3-7/8"	3-3/8"	3"	2-1/8"					
	thru Class 56	5-5/8"	4-1/4"	3-5/8"	3-1/4"	2-3/4"					
TAP SIZE 16 (actual size 15-1/2")	Class 50	5-3/4"	4-5/8"	4"	3-1/8"						
	thru Class 56	6-3/8"	5"	4-1/4"	3-1/2"						
TAP SIZE 18 (actual size 17-1/2")	Class 50	6-1/2"	5-1/4"	4"							
	thru Class 56	7-1/4"	5-5/8"	4-3/8"							
TAP SIZE 20 (actual size 19-1/2")	Class 50	7-1/4"	5-1/8"								
	thru Class 56	8"	5-1/2"								
TAP SIZE 24 (actual size 22-1/2")	Class 50	7-1/2"									
	thru Class 56	8-1/8"									

NOTE: Tap sizes 14" - 24" apply to TapMate XL only.

Ductile Iron Pipe

Nominal Size		30	36	42	48	54		60	64
PIPE OD		32.00	38.30	44.50	50.80	57.56		61.61	65.67
PIPE ID. SIZE RANGE	Class 50 thru Class 56	30.97 thru 30.49	37.19 thru 36.59	43.31 thru 42.59	49.53 thru 48.69	56.17 thru 55.21	Pressure Class 150 psi. thru Class 350 psi.	60.28 thru 59.70	64.30 thru 63.68
	***** TRAVEL DISTANCE *****								
(DISTANCE IS FROM WHERE CUTTER CONTACTING PIPE OD WALL - NOT THE PILOT)									
TAP SIZE 4 (actual size 3-1/2")	Class 50 thru Class 56	5/8" To 7/8"	5/8" To 1"	5/8" To 1-1/8"	5/8" To 1-1/8"	3/4" To 1-1/4"	Pressure Class 150 psi. thru Class 350 psi.	3/4" To 1"	3/4" To 1-1/8"
	TAP SIZE 6 (actual size 5-1/2")	3/4" To 1"	3/4" To 1-1/8"	3/4" To 1-1/8"	3/4" To 1-1/4"	7/8" To 1-3/8"	Pressure Class 150 psi. thru Class 350 psi.	7/8" To 1-1/8"	7/8" To 1-1/8"
TAP SIZE 8 (actual size 7-1/2")	1" To 1-1/4"	1" To 1-1/4"	7/8" To 1-1/4"	7/8" To 1-3/8"	7/8" To 1-1/2"	Pressure Class 150 psi. thru Class 350 psi.	1" To 1-1/4"	1" To 1-1/4"	
TAP SIZE 10 (actual size 9-1/2")	1-1/4" To 1-1/2"	1-1/4" To 1-1/2"	1-1/8" To 1-1/2"	1-1/8" To 1-5/8"	1-1/8" To 1-5/8"	Pressure Class 150 psi. thru Class 350 psi.	1-1/8" To 1-3/8"	1-1/8" To 1-3/8"	
TAP SIZE 12 (actual size 11-1/2")	1-5/8" To 1-7/8"	1-1/2" To 1-7/8"	1-3/8" To 1-3/4"	1-3/8" To 1-3/4"	1-1/4" To 1-7/8"	Pressure Class 150 psi. thru Class 350 psi.	1-1/4" To 1-5/8"	1-1/4" To 1-5/8"	
TAP SIZE 14 (actual size 13-1/2")	2" To 2-3/8"	1-3/4" To 2-1/4"	1-5/8" To 2-1/8"	1-1/2" To 2"	1-1/2" To 2-1/8"	Pressure Class 150 psi. thru Class 350 psi.	1-1/2" To 1-3/4"	1-1/2" To 1-3/4"	
TAP SIZE 16 (actual size 15-1/2")	2-5/8" To 2-7/8"	2-1/4" To 2-5/8"	2" To 2-1/2"	1-7/8" To 2-3/8"	1-3/4" To 2-3/8"	Pressure Class 150 psi. thru Class 350 psi.	1-3/4" To 2"	1-5/8" To 2"	
TAP SIZE 18 (actual size 17-1/2")	3-1/4" To 3-1/2"	2-3/4" To 3-1/8"	2-3/8" To 2-7/8"	2-1/4" To 2-3/4"	2-1/8" To 2-5/8"	Pressure Class 150 psi. thru Class 350 psi.	2" To 2-3/8"	2" To 2-1/4"	
TAP SIZE 20 (actual size 19-1/2")	4" To 4-3/8"	3-1/4" To 3-3/4"	2-7/8" To 3-3/8"	2-5/8" To 3-1/8"	2-3/8" To 3"	Pressure Class 150 psi. thru Class 350 psi.	2-3/8" To 2-5/8"	2-1/4" To 2-5/8"	
TAP SIZE 24 (actual size 22-1/2")	5-3/8" To 5-3/4"	4-3/8" To 4-3/4"	3-3/4" To 4-1/4"	3-3/8" To 3-7/8"	3" To 3-5/8"	Pressure Class 150 psi. thru Class 350 psi.	2-7/8" To 3-1/4"	2-3/4" To 3-1/8"	

NOTE: Tap sizes 14" - 24" apply to TapMate XL only.

C900 PVC PIPE

Nominal Size	4	6	8	10	12
PIPE OD	4.80	6.90	9.05	11.10	13.20

***** TRAVEL DISTANCE *****

(DISTANCE IS FROM WHERE CUTTER CONTACTING PIPE OD WALL - NOT THE PILOT)

TAP SIZE 4 (actual size 3-1/2")	DR 25	1-1/8"	7/8"	3/4" ~ 7/8"	3/4" ~ 7/8"	7/8"
	DR 18	1-1/4"	1"	1"	1" ~ 1-1/8"	1" ~ 1-1/8"
	DR 14	1-1/2"	1-1/8"~1-1/4"	1-1/8"~1-1/4"	1-1/8"~1-1/4"	1-1/4"~1-3/8"

TAP SIZE 6 (actual size 5-1/2")	DR 25	1-7/8"~2"	1-1/2"	1-1/4"~1-3/8"	1-1/4"~1-3/8"
	DR 18	2-1/8"~2-1/4"	1-5/8"~1-3/4"	1-1/2"~1-5/8"	1-1/2"~1-5/8"
	DR 14	2-3/8"~2-5/8"	1-7/8"~2"	1-3/4"~1-7/8"	1-5/8"~1-7/8"

TAP SIZE 8 (actual size 7-1/2")	DR 25	2-3/4"~2-7/8"	2-1/8"~2-1/4"	1-7/8" ~ 2"
	DR 18	3-1/8"~3-1/4"	2-3/8"~2-1/2"	2-1/8"~2-1/4"
	DR 14	35/8"~4"	2-5/8"~2-7/8"	2-3/8"~2-5/8"

TAP SIZE 10 (actual size 9-1/2")	DR 25	3-3/4"~3-7/8"	2-7/8" ~ 3"
	DR 18	4-1/4"~4-5/8"	3-1/4"~3-3/8"
	DR 14	SEE NOTE #1	3-5/8"~3-3/4"

TAP SIZE 12 (actual size 11-1/2")	DR 25	4-3/4"~4-7/8"
	DR 18	5-1/2"~6-1/8"
	DR 14	SEE NOTE #2

NOTE #1 : MUST USE A 9" ACTUAL OD CUTTER (P/N 350-01-2072)

4"~4-3/8"	TRAVEL
-----------	--------

NOTE #2 : MUST USE A 11" ACTUAL OD CUTTER (P/N 350-01-2088)

5-3/8"~6"	TRAVEL
-----------	--------

Nominal Size	4	6	8	10	12	
PIPE OD	4.80	6.90	9.05	11.10	13.20	
PIPE WALL & TOLERANCE	DR 25	0.192 + 0.023	0.276 + 0.033	0.362 + 0.043	0.444 + 0.053	0.528 + 0.063
	DR 18	0.267 + 0.032	0.383 + 0.046	0.503 + 0.060	0.617 + 0.074	0.733 + 0.088
	DR 14	0.343 + 0.041	0.493 + 0.059	0.646 + 0.078	0.793 + 0.095	0.943 + 0.113
PIPE ID. SIZE RANGE	DR 25	4.42 ~ 4.37	6.35 ~ 6.28	8.33 ~ 8.24	10.21 ~ 10.11	12.14 ~ 12.02
	DR 18	4.27 ~ 4.20	6.13 ~ 6.04	8.04 ~ 7.92	9.87 ~ 9.72	11.73 ~ 11.56
	DR 14	4.11 ~ 4.03	5.91 ~ 5.80	7.76 ~ 7.60	9.51 ~ 9.32	11.31 ~ 11.09

DR 25 (CLASS 100) ~ psi 165 RATING

DR 18 (CLASS 150) ~ psi 235 RATING

DR 14 (CLASS 200) ~ psi 305 RATING

TRAVEL CHARTS

C905 PVC pipe with CI outside diameter								
Nominal Size	14	16	18	20	24	30	36	
PIPE OD	15.30	17.40	19.50	21.60	25.80	32.00	38.30	
***** TRAVEL DISTANCE *****								
(DISTANCE IS FROM WHERE CUTTER CONTACTING PIPE OD WALL - NOT THE PILOT)								
TAP SIZE 4 (actual size 3-1/2")	DR 51			5/8"	3/4"	3/4"	7/8"	1"
	DR 41	3/4"	3/4"	3/4"	7/8"	7/8"	1"	1-1/4"
	DR 32.5	3/4"	7/8"	7/8"	1"	1-1/8"	1-1/4"	1-1/2"
	DR 25	1"	1"	1-1/8"	1-1/4"	1-3/8"	1-5/8"	1-7/8"
	DR 21	1-1/8"	1-1/4"	1-1/4"	1-3/8"	1-5/8"	1-7/8"	2-1/4"
	DR 18	1-1/4"	1-3/8"	1-1/2"	1-5/8"	1-7/8"	2-1/8"	
	DR 14	1-1/2"	1-5/8"	1-5/8"				
TAP SIZE 6 (actual size 5-1/2")	DR 51			7/8"	7/8"	1"	1"	1-1/8"
	DR 41	1"	1"	1"	1"	1-1/8"	1-1/4"	1-3/8"
	DR 32.5	1-1/8"	1-1/8"	1-1/8"	1-1/8"	1-1/4"	1-3/8"	1-5/8"
	DR 25	1/1/4"	1-3/8"	1-3/8"	1-3/8"	1-1/2"	1-3/4"	2"
	DR 21	1-1/2"	1-1/2"	1-1/2"	1-5/8"	1-1/2"	1-3/4"	2-3/8"
	DR 18	1-5/8"	1-3/4"	1-3/4"	1-7/8"	2"	2-3/8"	
	DR 14	1-7/8"	2"	1-7/8"				
TAP SIZE 8 (actual size 7-1/2")	DR 51			1-1/4"	1-1/4"	1-1/8"	1-1/4"	1-1/4"
	DR 41	1-1/2"	1-1/2"	1-3/8"	1-3/8"	1-3/8"	1-3/8"	1-1/2"
	DR 32.5	1-5/8"	1-5/8"	1-1/2"	1-1/2"	1-1/2"	1-5/8"	1-3/4"
	DR 25	1-7/8"	1-3/4"	1-3/4"	1-3/4"	1-7/8"	2"	2-1/8"
	DR 21	2"	2"	2"	2"	2"	2-1/4"	2-1/2"
	DR 18	2-1/8"	2-1/8"	2-1/8"	2-1/4"	2-3/8"	2-1/2"	
	DR 14	2-1/2"	2-1/2"	2-3/8"				
TAP SIZE 10 (actual size 9-1/2")	DR 51			1-3/4"	1-3/4"	1-5/8"	1-1/2"	1-1/2"
	DR 41	2-1/4"	2"	1-7/8"	1-7/8"	1-3/4"	1-3/4"	1-3/4"
	DR 32.5	2-3/8"	2-1/4"	2-1/8"	2"	1-7/8"	2"	2"
	DR 25	2-5/8"	2-3/8"	2-1/4"	2-1/4"	2-1/4"	2-1/4"	2-3/8"
	DR 21	2-3/4"	2-5/8"	2-1/2"	2-1/2"	2-1/2"	2-5/8"	2-3/4"
	DR 18	3"	2-7/8"	2-3/4"	2-3/4"	2-3/4"	2-7/8"	
	DR 14	3-3/8"	3-1/4"	2-7/8"				
TAP SIZE 12 (actual size 11-1/2")	DR 51			2-1/2"	2-3/8"	2"	1-7/8"	1-7/8"
	DR 41	3-3/8"	2-7/8"	2-5/8"	2-1/2"	2-1/4"	2-1/8"	2"
	DR 32.5	3-1/2"	3"	2-3/4"	2-5/8"	2-3/8"	2-1/4"	2-3/8"
	DR 25	3-3/4"	3-1/4"	3"	2-7/8"	2-3/4"	2-5/8"	2-3/4"
	DR 21	4"	3-1/2"	3-1/4"	3-1/8"	3"	3"	3-1/8"
	DR 18	4-1/4"	3-7/8"	3-1/2"	3-3/8"	3-1/4"	3-1/4"	
	DR 14	4-7/8"	4-1/4"	3-3/4"				
TAP SIZE 14 (actual size 13-1/2")	DR 51			3-3/8"	3"	2-5/8"	2-3/8"	2-1/4"
	DR 41	5-1/8"	4-1/8"	3-1/2"	3-1/4"	2-7/8"	2-1/2"	2-3/8"
	DR 32.5	5-1/2"	4-1/4"	3-3/4"	3-3/8"	3"	2-3/4"	2-3/4"
	DR 25	6"	4-5/8"	4"	3-3/4"	3-3/8"	3-1/8"	3-1/8"
	DR 21	6-5/8"	4-7/8"	4-1/4"	4"	3-5/8"	3-1/2"	3-1/2"
	DR 18	NOTE #1	5-3/8"	4-5/8"	4-1/4"	3-7/8"	3-3/4"	
	DR 14	NOTE #1	6"	4-7/8"				
TAP SIZE 16 (actual size 15-1/2")	DR 51			4-5/8"	4"	3-3/8"	2-7/8"	2-5/8"
	DR 41		6"	4-7/8"	4-1/4"	3-1/2"	3-1/8"	2-7/8"
	DR 32.5		6-3/8"	5-1/8"	4-1/2"	3-3/4"	3-3/8"	3-1/8"
	DR 25		7-1/8"	5-1/2"	4-3/4"	4-1/8"	3-3/4"	3-5/8"
	DR 21		8-1/4"	5-7/8"	5-1/4"	4-3/8"	4"	4"
	DR 18		NOTE #1	6-1/4"	5-1/2"	4-3/4"	4-3/8"	
	DR 14		NOTE #1	6-5/8"				
TAP SIZE 18 (actual size 17-1/2")	DR 51			6-5/8"	5-3/8"	4-1/4"	3-1/2"	3-1/8"
	DR 41			7"	5-5/8"	4-1/2"	3-3/4"	3-3/8"
	DR 32.5			7-3/8"	5-7/8"	4-3/4"	4"	3-5/8"
	DR 25			8-3/8"	6-3/8"	5-1/8"	4-3/8"	4-1/8"
	DR 21			NOTE #1	6-3/4"	5-1/2"	4-3/4"	4-1/2"
	DR 18			NOTE #1	7-1/4"	5-7/8"	5-1/8"	
	DR 14			NOTE #1				
TAP SIZE 20 (actual size 19-1/2")	DR 51			7-1/2"	5-3/8"	4-1/4"	3-3/4"	3-3/4"
	DR 41			7-7/8"	5-5/8"	4-1/2"	4-1/2"	4"
	DR 32.5			8-3/8"	6"	4-3/4"	4-3/4"	4-1/4"
	DR 25			9-5/8"	6-3/8"	5-1/4"	5-1/4"	4-3/4"
	DR 21			NOTE #1	6-7/8"	5-5/8"	5-5/8"	5-1/8"
	DR 18			NOTE #1	7-1/4"	6"	6"	
TAP SIZE 24 (actual size 22-1/2")	REQUIRES USE OF HDPE PILOT (STANDARD PVC PILOT WILL NOT WORK)				DR 51	7-7/8"	5-3/4"	4-3/4"
	NOTE #1 ~ STANDARD SIZE CUTTER WILL NOT WORK TOO LARGE FOR ID OF PIPE				DR 41	8-1/4"	6"	5"
					DR 32.5	8-3/4"	6-1/4"	5-3/8"
					DR 25	9-5/8"	6-3/4"	5-7/8"
					DR 21	10-1/2"	7-1/4"	6-3/8"
					DR 18	12"	7-3/4"	

NOTE: Tap sizes 14" - 24" apply to TapMate XL only.

C905 PVC pipe with CI outside diameter			
Nominal Size	42	48	
PIPE OD	44.50	50.80	

***** TRAVEL DISTANCE *****

DISTANCE IS FROM WHERE CUTTER CONTACTING PIPE OD WALL - NOT THE PILOT

REQUIRES USE OF HDPE PILOT
(STANDARD PVC PILOT WILL NOT WORK)

TAP SIZE 4 (actual size 3-1/2")	DR 51	1-1/8"	1-1/4"
	DR 41	1-3/8"	1-1/2"
	DR 32.5	1-5/8"	1-7/8"
	DR 25	2-1/8"	2-3/8"

TAP SIZE 6 (actual size 5-1/2")	DR 51	1-1/4"	1-3/8"
	DR 41	1-1/2"	1-5/8"
	DR 32.5	1-3/4"	2"
	DR 25	2-1/4"	2-1/2"

TAP SIZE 8 (actual size 7-1/2")	DR 51	1-3/8"	1-1/2"
	DR 41	1-5/8"	1-3/4"
	DR 32.5	1-7/8"	2-1/8"
	DR 25	2-3/8"	2-5/8"

TAP SIZE 10 (actual size 9-1/2")	DR 51	1-5/8"	1-5/8"
	DR 41	1-3/4"	1-7/8"
	DR 32.5	2-1/8"	2-1/4"
	DR 25	2-5/8"	2-7/8"

TAP SIZE 12 (actual size 11-1/2")	DR 51	1-7/8"	1-7/8"
	DR 41	2-1/8"	2-1/8"
	DR 32.5	2-3/8"	2-1/2"
	DR 25	2-7/8"	3"

TAP SIZE 14 (actual size 13-1/2")	DR 51	2-1/8"	2-1/8"
	DR 41	2-3/8"	2-1/2"
	DR 32.5	2-7/8"	2-3/4"
	DR 25	3-1/4"	NOTE #2

TAP SIZE 16 (actual size 15-1/2")	DR 51	2-1/2"	2-1/2"
	DR 41	2-3/4"	2-3/4"
	DR 32.5	3-1/8"	3-1/8"
	DR 25	3-5/8"	Note #2

TAP SIZE 18 (actual size 17-1/2")	DR 51	2-7/8"	2-7/8"
	DR 41	3-1/4"	3-1/8"
	DR 32.5	3-1/2"	3-1/2"
	DR 25	4"	Note #2

TAP SIZE 20 (actual size 19-1/2")	DR 51	3-3/8"	3-1/4"
	DR 41	3-3/4"	3-1/2"
	DR 32.5	4"	3-7/8"
	DR 25	4-1/2"	Note #2

TAP SIZE 24 (actual size 22-1/2")	DR 51	4-1/4"	4"
	DR 41	4-1/2"	4-1/4"
	DR 32.5	4-7/8"	4-5/8"
	DR 25	5-1/2"	Note #2

Note #2 ~ PVC WALL THICKNESS TOO MUCH FOR TM-XL PVC PILOT TO CUT THROUGH

PIPE WALL THICKNESS & TOLERANCE	Nominal Pipe OD	DR 51 Class 80	DR 41 Class 100	DR 32.5 Class 125	DR 25 Class 165	DR 21 Class 200	DR 18 Class 235	DR 14 Class 305
	14		0.373 + 0.052	0.471 + 0.056	0.612 + 0.073	0.729 + 0.088	0.850 + 0.102	1.093 + 0.131
	16		0.424 + 0.059	0.535 + 0.064	0.696 + 0.084	0.829 + 0.100	0.967 + 0.116	1.243 + 0.149
	18	0.382 + 0.053	0.476 + 0.067	0.600 + 0.072	0.780 + 0.094	0.929 + 0.111	1.083 + 0.130	1.393 + 0.167
	20	0.424 + 0.059	0.527 + 0.074	0.665 + 0.080	0.864 + 0.104	1.029 + 0.123	1.200 + 0.144	
	24	0.506 + 0.071	0.629 + 0.088	0.794 + 0.095	1.032 + 0.124	1.229 + 0.147	1.433 + 0.172	
	30	0.627 + 0.088	0.780 + 0.109	0.985 + 0.118	1.280 + 0.154	1.524 + 0.183	1.778 + 0.213	
	36	0.451 + 0.105	0.934 + 0.131	1.178 + 0.141	1.532 + 0.184	1.824 + 0.219		
	42	0.872 + 0.122	1.085 + 0.152	1.369 + 0.164	1.780 + 0.214			
	48	0.996 + 0.139	1.239 + 0.173	1.563 + 0.188	2.032 + 0.244			

PIPE ID. SIZE RANGE	Nominal Pipe OD	DR 51 Class 80	DR 41 Class 100	DR 32.5 Class 125	DR 25 Class 165	DR 21 Class 200	DR 18 Class 235	DR 14 Class 305
	14		14.55 ~ 14.45	14.36 ~ 14.25	14.08 ~ 13.93	13.84 ~ 13.67	13.60 ~ 13.40	13.11 ~ 12.85
	16		16.55 ~ 16.43	16.33 ~ 16.20	16.01 ~ 15.84	15.74 ~ 15.54	15.47 ~ 15.13	14.91 ~ 14.62
	18	18.74 ~ 18.63	18.55 ~ 18.41	18.30 ~ 18.16	17.94 ~ 17.75	17.64 ~ 17.42	17.33 ~ 17.07	17.10 ~ 16.77
	20	20.75 ~ 20.63	20.55 ~ 20.40	20.27 ~ 20.11	19.87 ~ 19.66	19.54 ~ 19.30	19.20 ~ 18.91	
	24	24.79 ~ 24.65	24.54 ~ 24.37	24.21 ~ 24.02	23.74 ~ 23.49	23.34 ~ 23.05	22.93 ~ 22.59	
	30	30.75 ~ 30.57	30.44 ~ 30.22	30.03 ~ 29.79	29.44 ~ 29.13	28.95 ~ 28.59	28.44 ~ 28.02	
	36	36.80 ~ 36.59	36.43 ~ 36.17	35.94 ~ 35.66	35.24 ~ 34.87	34.65 ~ 34.21		
	42	42.76 ~ 42.51	42.33 ~ 42.03	41.76 ~ 41.43	40.94 ~ 40.51			
	48	48.81 ~ 48.53	48.32 ~ 47.98	47.67 ~ 47.30	46.74 ~ 46.25			

NOTE: Tap sizes 14" - 24" apply to TapMate XL only.

TRAVEL CHARTS

C905 PVC pipe with IPS outside diameter								
Nominal Size	14	16	18	20	24	30	36	
PIPE OD	14.00	16.00	18.00	20.00	24.00	30.00	36.00	
***** TRAVEL DISTANCE *****								
(DISTANCE IS FROM WHERE CUTTER CONTACTING PIPE OD WALL - NOT THE PILOT)								
TAP SIZE 4 (actual size 3-1/2")	DR 41	5/8"	5/8"	3/4"	3/4"	7/8"	1"	1-1/8"
	DR 32.5	3/4"	3/4"	7/8"	7/8"	1"	1-1/8"	1-3/8"
	DR 25	7/8"	7/8"	1"	1"	1-1/8"	1-3/8"	1-5/8"
	DR 21	1"	1-1/8"	1-1/8"	1-1/4"	1/1/2"	1-3/4"	2"
TAP SIZE 6 (actual size 5-1/2")	DR 41	1"	1"	1"	1"	1"	1-1/8"	1-1/4"
	DR 32.5	1-1/8"	1-1/8"	1-1/8"	1-1/8"	1-1/8"	1-3/8"	1-1/2"
	DR 25	1-1/4"	1-1/4"	1-1/4"	1-1/4"	1-3/8"	1-5/8"	1-3/4"
	DR 21	1-3/4"	1-3/8"	1-1/2"	1-1/2"	1-5/8"	1-7/8"	2-1/8"
TAP SIZE 8 (actual size 7-1/2")	DR 41	1-5/8"	1-1/2"	1-3/8"	1-3/8"	1-3/8"	1-3/8"	1-1/2"
	DR 32.5	1-3/4"	1-5/8"	1-1/2"	1-1/2"	1-1/2"	1-5/8"	1-5/8"
	DR 25	1-7/8"	1-3/4"	1-5/8"	1-5/8"	1-3/4"	1-7/8"	2"
	DR 21	2"	2"	1-7/8"	1-7/8"	2"	2-1/8"	2-3/8"
TAP SIZE 10 (actual size 9-1/2")	DR 41	2-3/8"	2-1/8"	2"	1-7/8"	1-3/4"	1-5/8"	1-5/8"
	DR 32.5	2-1/2"	2-1/4"	2-1/8"	2"	1-7/8"	2-1/8"	2"
	DR 25	2-3/4"	2-1/2"	2-1/4"	2-1/4"	2-1/8"	2-1/8"	2-1/4"
	DR 21	3"	2-3/4"	2-1/2"	2-1/2"	2-3/8"	2-1/2"	2-5/8"
TAP SIZE 12 (actual size 11-1/2")	DR 41	3-3/4"	3-1/8"	2-3/4"	2-1/2"	2-1/4"	2"	2"
	DR 32.5	4"	3-1/4"	2-1/8"	2-5/8"	2-1/2"	2-1/4"	2-1/4"
	DR 25	4-1/4"	3-1/2"	3-1/8"	2-7/8"	2-5/8"	2-5/8"	2-5/8"
	DR 21	4-1/2"	3/3/4"	3-3/8"	3-1/8"	3"	2-7/8"	3"
TAP SIZE 14 (actual size 13-1/2")	DR 41	NOTE #1	4-5/8"	3-7/8"	3-3/8"	2-7/8"	2-1/2"	2-3/8"
	DR 32.5	NOTE #1	4-7/8"	4"	3-5/8"	3-1/8"	2-3/4"	2-5/8"
	DR 25	NOTE #1	5-1/4"	4-3/8"	3-7/8"	3-3/8"	3"	3"
	DR 21	NOTE #1	5-5/8"	4-5/8"	4-1/8"	3-5/8"	3-1/2"	NOTE #2
TAP SIZE 16 (actual size 15-1/2")	DR 41	NOTE #1	5-1/2"	4-5/8"	3-3/4"	3-1/8"	2-7/8"	2-7/8"
	DR 32.5	NOTE #1	5-7/8"	4-7/8"	4"	4"	3-3/8"	3-1/8"
	DR 25	NOTE #1	6-1/4"	5-1/8"	4-1/4"	3-5/8"	3-1/2"	3-1/2"
	DR 21	NOTE #1	6-7/8"	5-5/8"	4-5/8"	4"	NOTE #2	NOTE #2
TAP SIZE 18 (actual size 17-1/2")	DR 41	NOTE #1	6-1/2"	6-1/2"	4-3/4"	3-7/8"	3-1/2"	3-1/2"
	DR 32.5	NOTE #1	6-7/8"	6-7/8"	5"	4-1/8"	3-3/4"	3-3/4"
	DR 25	NOTE #1	7-3/8"	7-3/8"	5-3/8"	4-1/2"	4-1/8"	4-1/8"
	DR 21	NOTE #1	8-1/4"	8-1/4"	5-7/8"	4-7/8"	NOTE #2	NOTE #2
TAP SIZE 20 (actual size 19-1/2")	DR 41	NOTE #1	6-1/4"	6-1/4"	4-3/4"	4-3/4"	4-1/8"	4-1/8"
	DR 32.5	NOTE #1	6-1/2"	6-1/2"	5"	5"	4-3/8"	4-3/8"
	DR 25	NOTE #1	7"	7"	5-3/8"	5-3/8"	4-3/4"	4-3/4"
	DR 21	NOTE #1	7-1/2"	7-1/2"	5-7/8"	5-7/8"	NOTE #2	NOTE #2
TAP SIZE 24 (actual size 22-1/2")	REQUIRES USE OF HDPE PILOT (STANDARD PVC PILOT WILL NOT WORK)				DR 41	10-5/8"	6-3/8"	5-1/4"
	NOTE #1 ~ STANDARD SIZE CUTTER WILL NOT WORK TOO LARGE FOR ID OF PIPE				DR 32.5	NOTE #1	6-3/4"	5-5/8"
					DR 25	NOTE #1	7-1/8"	6"
					DR 21	NOTE #1	7-3/4"	NOTE #2

Note #2 ~ PVC WALL THICKNESS TOO MUCH FOR TM-XL PVC PILOT TO CUT THROUGH

PIPE WALL THICKNESS & TOLERANCE	Nominal Pipe OD	DR 41 Class 100	DR 32.5 Class 125	DR 25 Class 165	DR 21 Class 200
	14	0.341 + 0.048	0.430 + 0.052	0.538 + 0.064	0.666 + 0.080
	16	0.390 + 0.055	0.492 + 0.059	0.615 + 0.074	0.762 + 0.091
	18	0.439 + 0.061	0.554 + 0.066	0.692 + 0.083	0.857 + 0.103
	20	0.488 + 0.068	0.615 + 0.074	0.769 + 0.092	0.952 + 0.114
	24	0.585 + 0.082	0.738 + 0.088	0.923 + 0.111	1.143 + 0.137
	30	0.732 + 0.102	0.923 + 0.111	1.154 + 0.138	1.428 + 0.171
	36	0.878 + 0.123	1.108 + 0.133	1.385 + 0.166	1.714 + 0.205

PIPE ID. SIZE RANGE	Nominal Pipe OD	DR 41 Class 100	DR 32.5 Class 125	DR 25 Class 165	DR 21 Class 200
	14	13.32 ~ 13.22	13.14 ~ 13.04	12.92 ~ 12.80	12.67 ~ 12.51
	16	15.22 ~ 15.11	15.02 ~ 14.90	14.77 ~ 14.62	14.48 ~ 14.29
	18	17.12 ~ 17.00	16.89 ~ 16.76	16.62 ~ 16.45	16.29 ~ 16.08
	20	19.02 ~ 18.89	18.77 ~ 18.62	18.46 ~ 18.28	18.10 ~ 17.87
	24	22.83 ~ 22.67	22.52 ~ 22.35	22.15 ~ 21.93	21.71 ~ 21.44
	30	28.54 ~ 28.51	28.15 ~ 27.93	27.69 ~ 27.42	27.14 ~ 26.80
	36	34.24 ~ 34.00	33.78 ~ 33.52	33.23 ~ 32.90	32.57 ~ 32.16

C909 PVCO PIPE

Nominal Size	4	6	8	10	12
PIPE OD	4.80	6.90	9.05	11.10	13.20

***** TRAVEL DISTANCE *****

(DISTANCE IS FROM WHERE CUTTER CONTACTING PIPE OD WALL - NOT THE PILOT)

TAP SIZE 4 (actual size 3-1/2")	165 psi	1"	3/4"	5/8"	5/8"	5/8"
	235 psi	1"	3/4"	3/4"	3/4"	3/4"
	305 psi	1-1/8"	7/8"	7/8"	7/8"	7/8"

TAP SIZE 6 (actual size 5-1/2")	165 psi	1-3/4"	1-1/4"	1"	1"
	235 psi	1-7/8"	1-3/8"	1.1/4"	1-1/8"
	305 psi	2"	1-1/2"	1-3/8"	1-1/4"

TAP SIZE 8 (actual size 7-1/2")	165 psi	2-1/2"	1-7/8"	1-5/8"
	235 psi	2-5/8"	2"	1-3/4"
	305 psi	2-7/8"	2-1/4"	2"

TAP SIZE 10 (actual size 9-1/2")	165 psi	3-1/4"	2-1/2"
	235 psi	3-1/2"	2-3/4"
	305 psi	3-7/8"	3"

TAP SIZE 12 (actual size 11-1/2")	165 psi	4-1/8"
	235 psi	4-1/2"
	305 psi	5"

Nominal Size	4	6	8	10	12	
PIPE OD	4.80	6.90	9.05	11.10	13.20	
PIPE WALL & TOLERANCE	165 psi	0.109 + 0.013	0.157 + 0.019	0.206 + 0.025	0.252 + 0.030	0.300 + 0.036
	235 psi	0.154 + 0.018	0.221 + 0.027	0.290 + 0.035	0.356 + 0.043	0.423 + 0.051
	305 psi	0.198 + 0.024	0.284 + 0.034	0.373 + 0.045	0.457 + 0.055	0.544 + 0.065
PIPE ID. SIZE RANGE	165 psi	4.58 ~ 4.56	6.59 ~ 6.55	8.64 ~ 8.59	10.60 ~ 10.54	12.60 ~ 12.53
	235 psi	4.49 ~ 4.46	6.46 ~ 6.40	8.47 ~ 8.40	10.39 ~ 10.30	12.35 ~ 12.25
	305 psi	4.40 ~ 4.36	6.33 ~ 6.26	8.30 ~ 8.21	10.19 ~ 10.08	12.11 ~ 11.98

Nominal Size	14	16	18	20	24	
PIPE OD	15.30	17.40	19.50	21.60	25.80	
PIPE WALL & TOLERANCE	165 psi	0.347 + 0.042	0.395 + 0.047	0.443 + 0.053	0.491 + 0.059	0.586 + 0.070
	235 psi	0.490 + 0.059	0.557 + 0.067	0.625 + 0.075	0.692 + 0.083	0.827 + 0.099
	305 psi	0.630 + 0.076	0.717 + 0.086	0.803 + 0.096	0.890 + 0.107	1.063 + 0.128
PIPE ID. SIZE RANGE	165 psi	14.61 ~ 14.52	16.61 ~ 16.52	18.61 ~ 18.51	20.62 ~ 20.50	24.63 ~ 24.49
	235 psi	14.32 ~ 14.20	16.29 ~ 16.15	18.25 ~ 18.10	20.22 ~ 20.05	24.15 ~ 23.95
	305 psi	14.04 ~ 13.89	15.97 ~ 15.79	17.89 ~ 17.70	19.82 ~ 19.61	23.67 ~ 23.42

NOTE: Tap sizes 14" - 24" apply to TapMate XL only.

C909 PVCO PIPE

Nominal Size	14	16	18	20	24
PIPE OD	15.30	17.40	19.50	21.60	25.80

***** TRAVEL DISTANCE *****

(DISTANCE IS FROM WHERE CUTTER CONTACTING PIPE OD WALL - NOT THE PILOT)

TAP SIZE 4 <small>(actual size 3-1/2")</small>	<i>165 psi</i>	5/8"	5/8"	5/8"	3/4"	3/4"	
	<i>235 psi</i>	3/4"	7/8"	7/8"	1"	1"	
	<i>305 psi</i>	1"	1"	1-1/8"	1-1/8"	1-3/8"	
TAP SIZE 6 <small>(actual size 5-1/2")</small>	<i>165 psi</i>	1"	1"	1"	1"	1"	
	<i>235 psi</i>	1-1/8"	1-1/8"	1-1/8"	1-1/8"	1-1/4"	
	<i>305 psi</i>	1-1/4"	1-1/4"	1-3/8"	1-3/8"	1-1/2"	
TAP SIZE 8 <small>(actual size 7-1/2")</small>	<i>165 psi</i>	1-1/2"	1-3/8"	1-1/4"	1-1/4"	1-1/4"	
	<i>235 psi</i>	1-5/8"	1-1/2"	1-1/2"	1-1/2"	1-1/2"	
	<i>305 psi</i>	1-7/8"	1-3/4"	1-3/4"	1-3/4"	1-3/4"	
TAP SIZE 10 <small>(actual size 9-1/2")</small>	<i>165 psi</i>	2-1/8"	2"	1-7/8"	1-3/4"	1-5/8"	
	<i>235 psi</i>	2-3/8"	2-1/8"	2"	2"	2"	
	<i>305 psi</i>	2-5/8"	2-3/8"	2-1/4"	2-1/4"	2-1/4"	
TAP SIZE 12 <small>(actual size 11-1/2")</small>	<i>165 psi</i>	3-1/4"	2-3/4"	2-1/2"	2-3/8"	2-1/8"	
	<i>235 psi</i>	3-1/2"	3"	2-3/4"	2-5/8"	2-3/8"	
	<i>305 psi</i>	3-3/4"	3-1/4"	3"	2-7/8"	2-3/4"	
TAP SIZE 14 <small>(actual size 13-1/2")</small>	<i>165 psi</i>	5"	4"	3-1/2"	3-1/8"	2-3/4"	
	<i>235 psi</i>	5-1/2"	4-1/4"	3-3/4"	3-3/8"	3"	
	<i>305 psi</i>	6"	4-5/8"	4"	3/3/4"	3-3/8"	
TAP SIZE 16 <small>(actual size 15-1/2")</small>	<i>165 psi</i>		5-7/8"	4-3/4"	4-1/8"	3-1/2"	
	<i>235 psi</i>		6-1/2"	5"	4-1/2"	3-3/4"	
	<i>305 psi</i>		7-1/8"	5-1/2"	4-3/4"	4-1/8"	
TAP SIZE 18 <small>(actual size 17-1/2")</small>	<i>165 psi</i>			6-3/4"	5-1/2"	4-3/8"	
	<i>235 psi</i>			7-1/2"	6"	4-3/4"	
	<i>305 psi</i>			8-1/2"	6-3/8"	5-1/8"	
TAP SIZE 20 <small>(actual size 19-1/2")</small>	<i>165 psi</i>				7-5/8"	5-1/2"	
	<i>235 psi</i>				8-1/2"	6"	
	<i>305 psi</i>				9-3/4"	6-1/2"	
TAP SIZE 24 <small>(actual size 22-1/2")</small>	REQUIRES USE OF HDPE PILOT (STANDARD PVC PILOT WILL NOT WORK)					<i>165 psi</i>	8-1/8"
						<i>235 psi</i>	8-7/8"
						<i>305 psi</i>	9-5/8"

ASTM D2241 - IPS PVC Pipe

Nominal Size	4	5	6	8	10	12	14
PIPE OD	4.50	5.56	6.63	8.63	10.75	12.75	14.00

***** TRAVEL DISTANCE *****

(DISTANCE IS FROM WHERE CUTTER CONTACTING PIPE OD WALL - NOT THE PILOT)

TAP SIZE 4 (actual size 3-1/2")	SDR 64	1"	3/4"	5/8"	5/8"	1/2"	1/2"	5/8"
	SDR 41	1-1/8"	7/8"	3/4"	5/8"	5/8"	5/8"	
	SDR 32.5	1-1/8"	7/8"	7/8"	3/4"	3/4"	3/4"	
	SDR 26	1-1/4"	1"	7/8"	7/8"	7/8"	7/8"	
	SDR 21	1-1/4"	1"	1"	7/8"	1"	1"	
	SDR 17	1-3/8"	1-1/8"	1-1/8"	1"	1-1/8"	1-1/8"	

TAP SIZE 6 (actual size 5-1/2")	SDR 64	1-3/4"	1-1/4"	1"	7/8"	1"
	SDR 41	1-7/8"	1-3/8"	1-1/8"	1-1/8"	
	SDR 32.5	2"	1/3/8"	1-1/4"	1-1/4"	
	SDR 26	2-1/8"	1-1/2"	1-1/4"	1-1/4"	
	SDR 21	2-1/4"	1-5/8"	1-1/2"	1-1/2"	
	SDR 17	2-1/2"	1-7/8"	1-5/8"	1-5/8"	

TAP SIZE 8 (actual size 7-1/2")	SDR 64	2-5/8"	1-7/8"	1-1/2"	1-5/8"
	SDR 41	2-3/4"	2"	1-3/4"	
	SDR 32.5	2-7/8"	2-1/8"	1-7/8"	
	SDR 26	3-1/8"	2-1/4"	2"	
	SDR 21	3-1/2"	2-3/8"	2-1/8"	
	SDR 17	4-3/8"	2-5/8"	2-3/8"	

TAP SIZE 10 (actual size 9-1/2")	SDR 64	3-3/8"	2-1/2"	2-1/2"
	SDR 41	3-5/8"	2-3/4"	
	SDR 32.5	3-7/8"	2-7/8"	
	SDR 26	4-1/8"	3"	
	SDR 21	4-3/4"	3-1/4"	
	SDR 17	5-3/8"	3-5/8"	

TAP SIZE 12 (actual size 11-1/2")	SDR 64	4-1/4"	3-3/4"
	SDR 41	4-5/8"	
	SDR 32.5	5"	
	SDR 26	5-1/2"	
	SDR 21	Note #1	
	SDR 17	Note #1	

NOTE #1 ~: MUST USE A 11" ACTUAL OD CUTTER (P/N 350-01-2088)
SDR 21 ~ Travel = 4-7/8" SDR 17 ~ Travel = 5-3/4"

TAP SIZE 14 (actual size 13-1/2")	NOTE #2 ~ STANDARD SIZE CUTTER WILL NOT WORK TOO LARGE FOR ID OF PIPE		SDR 41	Note #2
	REQUIRES USE OF HDPE PILOT (STANDARD PVC PILOT WILL NOT WORK)		SDR 32.5	Note #2
			SDR 26	Note #2

Nominal Size		4	5	6	8	10	12	14		
PIPE WALL & TOLERANCE	Class 80	SDR 64	0.070 + 0.020	0.087 + 0.020	0.104 + 0.020	0.135 + 0.020	0.168 + 0.020	0.199 + 0.024	0.314 + 0.048	
	Class 100	SDR 41	0.110 + 0.020	0.136 + 0.020	0.162 + 0.020	0.210 + 0.025	0.262 + 0.031	0.311 + 0.037		
		SDR 32.5	0.138 + 0.020	0.171 + 0.021	0.204 + 0.024	0.265 + 0.32	0.331 + 0.040	0.392 + 0.047		0.043 + 0.052
	Class 128	SDR 26	0.173 + 0.020	0.214 + 0.027	0.255 + 0.031	0.332 + 0.040	0.413 + 0.050	0.490 + 0.059		0.538 + 0.064
	Class 160	SDR 21	0.214 + 0.026	0.265 + 0.32	0.316 + 0.038	0.410 + 0.049	0.511 + 0.061	0.606 + 0.073		0.666 + 0.080
	Class 200	SDR 17	0.265 + 0.032	0.327 + 0.039	0.390 + 0.047	0.508 + 0.061	0.632 + 0.076	0.750 + 0.090		0.823 + 0.099
Class	SDR 13.5	0.333 + 0.040	0.412 + 0.049	0.491 + 0.059						
PIPE ID. SIZE RANGE	Class 80	SDR 64	4.36 ~ 4.32	5.39 ~ 5.35	6.42 ~ 6.38	8.36 ~ 8.32	10.41 ~ 10.37	12.35 ~ 12.30	13.32 ~ 13.22	
	Class 100	SDR 41	4.28 ~ 4.24	5.29 ~ 5.25	6.30 ~ 6.26	8.21 ~ 8.16	10.23 ~ 10.16	12.13 ~ 12.05		
		SDR 32.5	4.22 ~ 4.18	5.22 ~ 5.18	6.22 ~ 6.17	8.10 ~ 8.03	10.09 ~ 10.01	11.97 ~ 11.87		13.14 ~ 13.04
	Class 128	SDR 26	4.15 ~ 4.11	5.13 ~ 5.08	6.12 ~ 6.05	7.96 ~ 7.88	9.92 ~ 9.82	11.77 ~ 11.65		12.92 ~ 12.80
	Class 160	SDR 21	4.07 ~ 4.02	5.03 ~ 4.97	5.99 ~ 5.92	7.81 ~ 7.71	9.73 ~ 9.61	11.54 ~ 11.39		12.67 ~ 12.51
	Class 200	SDR 17	3.97 ~ 3.91	4.91 ~ 4.83	5.85 ~ 5.75	7.61 ~ 7.49	9.49 ~ 9.33	11.25 ~ 11.07		12.35 ~ 12.16
Class	SDR 13.5	3.83 ~ 3.75	4.74 ~ 4.64	5.64 ~ 5.53						

Nominal Size		16	18	20	24	30	36	
PIPE WALL & TOLERANCE	Class 100	SDR 41	0.390 + 0.055	0.439 + 0.061	0.488 + 0.068	0.585 + 0.082	0.732 + 0.102	0.878 + 0.123
		SDR 32.5	0.492 + 0.059	0.554 + 0.066	0.615 + 0.074	0.738 + 0.088	0.923 + 0.111	1.108 + 0.133
	Class 128	SDR 26	0.615 + 0.074	0.692 + 0.083	0.769 + 0.092	0.923 + 0.111	1.154 + 0.138	1.385 + 0.166
	Class 160	SDR 21	0.762 + 0.091	0.857 + 0.103	0.952 + 0.114	1.143 + 0.137	1.428 + 0.171	1.714 + 0.205
	Class 200	SDR 17	0.941 + 0.113	1.059 + 0.127	1.176 + 0.141	1.412 + 0.169	1.765 + 0.212	2.118 + 0.254
PIPE ID. SIZE RANGE	Class 100	SDR 41	15.22 ~ 15.11	17.12 ~ 17.00	19.02 ~ 18.89	22.83 ~ 22.67	28.54 ~ 28.33	34.24 ~ 34.00
		SDR 32.5	15.02 ~ 14.90	16.89 ~ 16.76	18.77 ~ 18.62	22.52 ~ 22.35	28.15 ~ 27.93	33.78 ~ 33.52
	Class 128	SDR 26	14.77 ~ 14.62	16.62 ~ 16.45	18.46 ~ 18.28	22.15 ~ 21.93	27.69 ~ 27.42	33.23 ~ 32.90
	Class 160	SDR 21	14.48 ~ 14.29	16.29 ~ 16.08	18.10 ~ 17.87	21.71 ~ 21.44	27.14 ~ 27.11	32.57 ~ 32.16
	Class 200	SDR 17	14.12 ~ 13.89	15.88 ~ 15.63	17.65 ~ 17.37	21.18 ~ 20.84	26.47 ~ 26.05	31.76 ~ 31.26

NOTE: Tap sizes 14" - 24" apply to TapMate XL only.

TRAVEL CHARTS

ASTM D2241 - IPS PVC Pipe

Nominal Size	16	18	20	24	30	36
PIPE OD	16.00	18.00	20.00	24.00	30.00	36.00

***** TRAVEL DISTANCE *****

(DISTANCE IS FROM WHERE CUTTER CONTACTING PIPE OD WALL - NOT THE PILOT)

TAP SIZE 4 (actual size 3-1/2")	SDR 41	3/4"	3/4"	3/4"	7/8"	1"	1-1/8"
	SDR 32.5	7/8"	7/8"	7/8"	1"	1-1/4"	1-3/8"
	SDR 26	1"	1"	1-1/8"	1-1/4"	1-1/2"	1-3/4"
	SDR 21	1-1/8"	1-1/4"	1-1/4"	1-1/2"	1-5/8"	2-1/8"
	SDR 17	1-3/8"	1-1/2"	1-1/2"	1-3/4"	2-1/8"	2-1/2"

TAP SIZE 6 (actual size 5-1/2")	SDR 41	1"	1"	1"	1"	1-1/8"	1-1/4"
	SDR 32.5	1-1/8"	1-1/8"	1-1/8"	1-1/4"	1-3/8"	1-1/2"
	SDR 26	1-1/4"	1-1/4"	1-3/8"	1-1/2"	1-5/8"	1-7/8"
	SDR 21	1-1/2"	1-1/2"	1-1/2"	1-3/4"	1-3/4"	2-1/4"
	SDR 17	1-5/8"	1-3/4"	1-7/8"	2"	2-3/8"	2-5/8"

TAP SIZE 8 (actual size 7-1/2")	SDR 41	1-1/2"	1-3/8"	1-3/8"	1-3/8"	1-3/8"	1-1/2"
	SDR 32.5	1-5/8"	1-1/2"	1-1/2"	1-1/2"	1-5/8"	1-3/4"
	SDR 26	1-3/4"	1-3/4"	1-3/4"	1-3/4"	1-7/8"	2"
	SDR 21	2"	2"	2"	2"	2"	2-3/8"
	SDR 17	2-1/4"	2-1/4"	2-1/4"	2-3/8"	2-5/8"	2-7/8"

TAP SIZE 10 (actual size 9-1/2")	SDR 41	2-1/8"	2"	1-7/8"	1-3/4"	1-3/4"	1-3/4"
	SDR 32.5	2-1/4"	2-1/8"	2"	2"	1-7/8"	2"
	SDR 26	2-1/2"	2-3/8"	2-1/4"	2-1/4"	2-1/4"	2-3/8"
	SDR 21	2-5/8"	2-5/8"	2-1/2"	2-1/2"	2-3/8"	2-3/4"
	SDR 17	3"	2-7/8"	2-3/4"	2-3/4"	3"	3-1/8"

TAP SIZE 12 (actual size 11-1/2")	SDR 41	3-1/8"	2-3/4"	2-1/2"	2-1/4"	2-1/8"	2"
	SDR 32.5	3-1/4"	3"	2-3/4"	2-1/2"	2-3/8"	2-3/8"
	SDR 26	3-1/2"	3-1/4"	3"	2-3/4"	2-5/8"	2-5/8"
	SDR 21	3-3/4"	3-3/8"	3-1/4"	3"	2-3/4"	3"
	SDR 17	4-1/8"	3-3/4"	3-1/2"	3-3/8"	3-3/8"	3-1/2"

TAP SIZE 14 (actual size 13-1/2")	SDR 41	4-5/8"	3-7/8"	3-1/2"	3"	2-5/8"	2-1/2"
	SDR 32.5	4-7/8"	4-1/8"	3-5/8"	3-1/8"	2-7/8"	2-3/4"
	SDR 26	5-1/4"	4-3/8"	3-7/8"	3-3/8"	3-1/8"	3"
	SDR 21	5-5/8"	4-5/8"	4-1/4"	3-3/4"	3-1/4"	3-1/2"
	SDR 17	6-3/8"	5-1/8"	4-5/8"	4-1/8"	4"	Note #3

TAP SIZE 16 (actual size 15-1/2")	SDR 41	Note #2	5-1/2"	4-5/8"	3-3/4"	3-1/8"	2-7/8"
	SDR 32.5	Note #2	5-7/8"	4-7/8"	4"	3-1/2"	3-1/4"
	SDR 26	Note #2	6-1/4"	5-1/4"	4-1/4"	3-3/4"	3-1/2"
	SDR 21	Note #2	6-7/8"	5-5/8"	4-5/8"	4"	4"
	SDR 17	Note #2	8"	6-1/8"	5-1/8"	4-5/8"	Note #3

TAP SIZE 18 (actual size 17-1/2")	SDR 41	Note #2	Note #2	6-1/2"	4-7/8"	3-7/8"	3-1/2"
	SDR 32.5	Note #2	Note #2	6-7/8"	5-1/8"	4-1/8"	3-3/4"
	SDR 26	Note #2	Note #2	7-3/8"	5-3/8"	4-1/2"	4-1/8"
	SDR 21	Note #2	Note #2	8-1/4"	5-7/8"	4-3/4"	5-5/8"
	SDR 17	Note #2	Note #2	see note	6-3/8"	5-3/8"	Note #3

TAP SIZE 20 (actual size 19-1/2")	SDR 41	Note #2	Note #2	6-1/4"	4-3/4"	4-1/8"	4-1/8"
	SDR 32.5	Note #2	Note #2	6-5/8"	5"	4-1/2"	4-1/2"
	SDR 26	Note #2	Note #2	7"	5-3/8"	4-7/8"	4-7/8"
	SDR 21	Note #2	Note #2	7-5/8"	5-5/8"	5-1/4"	5-1/4"
	SDR 17	Note #2	Note #2	8-3/8"	6-3/8"	Note #3	Note #3

TAP SIZE 24 (actual size 22-1/2")	SDR 41	Note #2	Note #2	10-5/8"	6-1/2"	5-3/8"	5-3/8"
	SDR 32.5	Note #2	Note #2	Note #2	6-3/4"	5-5/8"	5-5/8"
	SDR 26	Note #2	Note #2	Note #2	7-1/4"	6"	6"
	SDR 21	Note #2	Note #2	Note #2	7-1/2"	6-5/8"	6-5/8"
	SDR 17	Note #2	Note #2	Note #2	8-1/2"	Note #3	Note #3

NOTE #2 ~ STANDARD SIZE CUTTER WILL NOT WORK TOO LARGE FOR ID OF PIPE

REQUIRES USE OF HDPE PILOT (STANDARD PVC PILOT WILL NOT WORK)

Note #3 ~ PVC WALL THICKNESS TOO MUCH FOR TM-XL PVC PILOT TO CUT THROUGH

ASTM D1785 - IPS PVC Pipe, Schedule 40, 80, and 120

Nominal Size	4	5	6	8	10	12
PIPE OD	4.50	5.56	6.63	8.63	10.75	12.75

***** TRAVEL DISTANCE *****

(DISTANCE IS FROM WHERE CUTTER CONTACTING PIPE OD WALL - NOT THE PILOT)

TAP SIZE 4 (actual size 3-1/2")	Sch 40	1-3/8"	1"	7/8"	3/4"	3/4"	3/4"
	Sch 80	1-5/8"	1-1/4"	1-1/8"	1"	1"	1-1/8"
	Sch 120	2-1/8"	1-1/2"	1-3/8"	1-3/8"	1-3/8"	1-1/2"
TAP SIZE 6 (actual size 5-1/2")	Sch 40		2-1/4"	1-1/2"	1-1/4"	1-1/4"	1-1/8"
	Sch 80		2-5/8"	1-3/4"	1-5/8"	1-5/8"	1-1/2"
	Sch 120		Note #1	2-1/8"	2"	2"	2"
TAP SIZE 8 (actual size 7-1/2")	Sch 40		3-1/8"	2-1/8"	1-7/8"	1-7/8"	1-7/8"
	Sch 80		4-1/4"	2-5/8"	2-1/4"	2-1/4"	2-1/4"
	Sch 120		Note #2	3-1/8"	2-3/4"	2-3/4"	2-3/4"
TAP SIZE 10 (actual size 9-1/2")	Sch 40		4"	2-7/8"	2-7/8"	2-7/8"	2-7/8"
	Sch 80		Note #3	3-1/2"	3-1/2"	3-1/2"	3-1/2"
	Sch 120		Note #5	4-1/8"	4-1/8"	4-1/8"	4-1/8"
TAP SIZE 12 (actual size 11-1/2")	REQUIRES USE OF HDPE PILOT (STANDARD PVC PILOT WILL NOT WORK)					Sch 40	5"
						Sch 80	Note #4
						Sch 120	Note #5

- Note #1 MUST USE A 5" ACTUAL OD CUTTER (P/N 350-01-2040) Sch 120 ~ Travel = 2-3/8"
- Note #2 MUST USE A 7" ACTUAL OD CUTTER (P/N 350-01-2056) Sch 120 ~ Travel = 4"
- Note #3 MUST USE A 9" ACTUAL OD CUTTER (P/N 350-01-2072) Sch 80 ~ Travel = 4"
- Note #4 MUST USE A 11" ACTUAL OD CUTTER (P/N 350-01-2088) Sch 80 ~ Travel = 5-1/4"
- Note #5 STANDARD SIZE CUTTER WILL NOT WORK ~ TOO LARGE FOR ID OF PIPE

Nominal Size	4	5	6	8	10	12	
PIPE WALL & TOLERANCE	Sch 40	0.237 + 0.028	0.258 + 0.031	0.280 + 0.034	0.322 + 0.039	0.365 + 0.044	0.406 + 0.049
	Sch 80	0.337 + 0.040	0.375 + 0.045	0.432 + 0.052	0.500 + 0.060	0.593 + 0.071	0.687 + 0.082
	Sch 120	0.437 + 0.052	0.500 + 0.060	0.562 + 0.067	0.718 + 0.086	0.843 + 0.101	1.000 + 0.120
PIPE ID. SIZE RANGE	Sch 40	4.03 ~ 3.97	5.04 ~ 4.98	6.07 ~ 6.00	7.99 ~ 7.91	10.02 ~ 9.93	11.94 ~ 11.84
	Sch 80	3.83 ~ 3.75	4.81 ~ 4.72	5.77 ~ 5.66	7.63 ~ 7.51	9.56 ~ 9.42	11.38 ~ 11.21
	Sch 120	3.63 ~ 3.52	4.56 ~ 4.44	5.51 ~ 5.37	7.19 ~ 7.02	9.06 ~ 8.86	10.75 ~ 10.51

Nominal Size	14	16	18	20	24	
PIPE WALL & TOLERANC S	Sch 40	0.437 + 0.053	0.500 + 0.060	0.562 + 0.067	0.593 + 0.071	0.687 + 0.082
	Sch 80	0.750 + 0.090	0.843 + 0.101	0.937 + 0.112	1.031 + 0.124	1.218 + 0.146
PIPE ID. SIZE RANGE	Sch 40	13.13 ~ 13.02	15.00 ~ 14.88	16.88 ~ 16.74	18.81 ~ 18.67	22.63 ~ 22.46
	Sch 80	12.50 ~ 12.32	14.31 ~ 14.11	16.13 ~ 15.90	17.94 ~ 17.69	21.56 ~ 21.27

NOTE: Tap sizes 14" - 24" apply to TapMate XL only.

ASTM 1785 - IPS PVC Pipe, Schedule 40, 80, and 120						
Nominal Size	14	16	18	20	24	
PIPE OD	14.00	16.00	18.00	20.00	24.00	
***** TRAVEL DISTANCE *****						
(DISTANCE IS FROM WHERE CUTTER CONTACTING PIPE OD WALL - NOT THE PILOT)						
TAP SIZE 4 (actual size 3-1/2")	Sch 40	3/4"	7/8"	7/8"	7/8"	1"
	Sch 80	1-1/8"	1-1/4"	1-1/4"	1-3/8"	1-1/2"
TAP SIZE 6 (actual size 5-1/2")	Sch 40	1-1/8"	1-1/8"	1-1/8"	1-1/8"	1-1/8"
	Sch 80	1-1/2"	1-1/2"	1-5/8"	1-5/8"	1-3/4"
TAP SIZE 8 (actual size 7-1/2")	Sch 40	1-3/4"	1-5/8"	1-1/2"	1-1/2"	1-1/2"
	Sch 80	2-1/8"	2"	2"	2"	2-1/8"
TAP SIZE 10 (actual size 9-1/2")	Sch 40	2-5/8"	2-3/8"	2-1/8"	2"	1-7/8"
	Sch 80	3-1/8"	2-7/8"	2-5/8"	2-5/8"	2-1/2"
TAP SIZE 12 (actual size 11-1/2")	Sch 40	4"	3-3/8"	3"	2-5/8"	2-3/8"
	Sch 80	4-7/8"	4"	3-1/2"	3-3/8"	3-1/8"
TAP SIZE 14 (actual size 13-1/2")	Sch 40	Note #5	4-7/8"	4-1/8"	3-5/8"	3-1/8"
	Sch 80	Note #5	6"	4-7/8"	4-3/8"	3-7/8"
TAP SIZE 16 (actual size 15-1/2")	Sch 40	Note #5	Note #5	5-7/8"	4-7/8"	3-7/8"
	Sch 80	Note #5	Note #5	7-1/4"	5-3/4"	4-3/4"
TAP SIZE 18 (actual size 17-1/2")	Sch 40	Note #5	Note #5	Note #5	6-3/4"	5"
	Sch 80	Note #5	Note #5	Note #5	8-3/4"	6"
TAP SIZE 20 (actual size 19-1/2")	Sch 40	Note #5	Note #5	Note #5	Note #5	6-1/2"
	Sch 80	Note #5	Note #5	Note #5	Note #5	7-3/4"
TAP SIZE 24 (actual size 22-1/2")	Sch 40	Note #5	Note #5	Note #5	Note #5	12"
	Sch 80	Note #5	Note #5	Note #5	Note #5	Note #5

Note #5 STANDARD SIZE CUTTER WILL NOT WORK ~ TOO LARGE FOR ID OF PIPE

REQUIRES USE OF HDPE PILOT
(STANDARD PVC PILOT WILL NOT WORK)

TRAVEL CHARTS

HDPE							
Nominal Size	10		12		14	16	18
PIPE OD	10.75	11.10	12.75	13.20	14.00	16.00	18.00
***** TRAVEL DISTANCE *****							
(DISTANCE IS FROM WHERE CUTTER CONTACTING PIPE OD WALL - NOT THE PILOT)							
TAP SIZE 4 (actual size 3-1/2")	SDR 21	7/8"	7/8"	1"	1"	1-1/8"	1-1/8"
	SDR 17	1"	1-1/8"	1-1/8"	1-1/4"	1-1/4"	1-1/4"
	SDR 13.5	1-1/4"	1-1/4"	1-3/8"	1-1/2"	1-5/8"	1-5/8"
	SDR 11	1-3/8"	1-1/2"	1-5/8"	1-3/4"	1-7/8"	1-7/8"
	SDR 9	1-5/8"	1-3/4"	1-7/8"	2-1/8"	2-1/4"	2-1/4"
	SDR 7	2"	2-1/4"	2-3/8"	2-5/8"		
TAP SIZE 6 (actual size 5-1/2")	SDR 21	1-3/8"	1-3/8"	1-3/8"	1-3/8"	1-3/8"	1-3/8"
	SDR 17	1-1/2"	1-1/2"	1-1/2"	1-1/2"	1-5/8"	1-5/8"
	SDR 13.5	1-3/4"	1-3/4"	1-3/4"	1-7/8"	1-7/8"	1-7/8"
	SDR 11	2"	2"	2"	2-1/8"	2-1/4"	2-1/4"
	SDR 9	2-1/4"	2-3/8"	2-3/8"	2-1/2"	2-5/8"	2-5/8"
	SDR 7	2-3/4"	2-3/4"	2-7/8"	3"		
TAP SIZE 8 (actual size 7-1/2")	SDR 21	2-1/4"	2"	2"	1-7/8"	1-7/8"	1-7/8"
	SDR 17	2-1/2"	2-1/4"	2-1/8"	2-1/8"	2"	2"
	SDR 13.5	2-3/4"	2-1/2"	2-3/8"	2-3/8"	2-3/8"	2-3/8"
	SDR 11	3-1/8"	2-3/4"	2-3/4"	2-5/8"	2-3/4"	2-3/4"
	SDR 9	3-1/2"	3-1/8"	3-1/8"	3-1/8"	3-1/8"	3-1/8"
	SDR 7	4-5/8"	3-7/8"	3-3/4"	3-3/4"		
TAP SIZE 10 (actual size 9-1/2")	SDR 21	4-3/8"	4"	3-1/8"	2-7/8"	2-5/8"	2-1/2"
	SDR 17	Note #4	4-3/8"	3-3/8"	3-1/8"	2-7/8"	2-3/4"
	SDR 13.5	Note #4	NOTE #4	3-3/4"	3-1/2"	3-1/8"	3"
	SDR 11		NOTE #4	4-1/4"	3-7/8"	3-1/2"	3-3/8"
	SDR 9			5"	4-3/8"	4"	3-7/8"
	SDR 7			NOTE #4	5-1/2"	4-7/8"	
TAP SIZE 12 (actual size 11-1/2")	SDR 21		6"	5"	4-3/8"	3-5/8"	3-1/4"
	SDR 17		NOTE #5	5-3/4"	4-3/4"	4"	3-5/8"
	SDR 13.5			NOTE #5	5-1/2"	4-3/8"	4"
	SDR 11				NOTE #5	4-7/8"	4-1/2"
	SDR 9					5-5/8"	5-1/8"
	SDR 7					7-1/4"	
TAP SIZE 14 (actual size 13-1/2")	SDR 21				NOTE #6	5-1/2"	4-1/2"
	SDR 17				NOTE #6	6"	4-7/8"
	SDR 13.5				NOTE #6	7-1/8"	5-3/8"
	SDR 11				NOTE #6	NOTE #6	6-1/8"
	SDR 9				NOTE #6	NOTE #6	NOTE #7
	SDR 7				NOTE #7	NOTE #7	
TAP SIZE 16 (actual size 15-1/2")	SDR 21				NOTE #6		6-1/2"
	SDR 17				NOTE #6		7-3/8"
	SDR 13.5				NOTE #6		NOTE #6
	SDR 11				NOTE #6		NOTE #6
	SDR 9				NOTE #6		NOTE #7
	SDR 7				NOTE #7		
TAP SIZE 18 (actual size 17-1/2")	SDR 21				NOTE #6		NOTE #6
	SDR 17				NOTE #6		NOTE #6
	SDR 13.5				NOTE #6		NOTE #6
	SDR 11				NOTE #6		NOTE #6
	SDR 9				NOTE #6		NOTE #7

NOTES: STANDARD SIZE CUTTER WILL NOT WORK ~ TOO LARGE FOR ID OF PIPE

NOTE #4 :USE 9" ACTUAL OD CUTTER (P/N 350-01-2072)

3-7/8"
4-1/2"
5-1/4"

10" IPS ~ SDR 17 TRAVEL
10" IPS ~ SDR 13.5 TRAVEL
12" IPS ~ SDR 7 TRAVEL

4-1/8"
5"

10" DI ~ SDR 13.5 TRAVEL
10" DI ~ SDR 11 TRAVEL

NOTE #5 :USE 11" ACTUAL OD CUTTER (P/N 350-01-2088)

5-1/4"
5-3/8"

12" IPS ~ SDR 17 TRAVEL
14" IPS ~ SDR 11 TRAVEL

5-1/2"

12" DI ~ SDR 13.5 TRAVEL

NOTE #6 ~NO CUTTER CURRENTLY AVAILABLE ~

NOTE #7 ~ PIPE WALL THICKNESS TOO MUCH FOR TM-XL PVC PILOT TO CUT THROUGH

NOTE: Tap sizes 14" - 24" apply to TapMate XL only.

HDPE						
Nominal Size		20		22	24	
PIPE OD		20.00	21.60	22.00	24.00	25.80
***** TRAVEL DISTANCE *****						
(DISTANCE IS FROM WHERE CUTTER CONTACTING PIPE OD WALL - NOT THE PILOT)						
TAP SIZE 4 (actual size 3-1/2")	SDR 21	1-1/8"	1-1/4"	1-1/4"	1-3/8"	1-3/8"
	SDR 17	1-3/8"	1-1/2"	1-1/2"	1-5/8"	1-5/8"
	SDR 13.5	1-3/4"	1-3/4"	1-7/8"	2"	2"
	SDR 11	2"	2-1/8"	2-1/4"	2-3/8"	2-1/2"
	SDR 9	2-1/2"	2-5/8"	2-5/8"	2-7/8"	3"
TAP SIZE 6 (actual size 5-1/2")	SDR 21	1-3/8"	1-3/8"	1-1/2"	1-1/2"	1-1/2"
	SDR 17	1-5/8"	1-5/8"	1-3/4"	1-7/8"	1-7/8"
	SDR 13.5	2"	2"	2-1/8"	2-1/4"	2-1/4"
	SDR 11	2-3/8"	2-3/8"	2-1/2"	2-5/8"	2-3/4"
	SDR 9	2-3/4"	2-7/8"	3"	3-1/8"	3-1/4"
TAP SIZE 8 (actual size 7-1/2")	SDR 21	1-3/4"	1-3/4"	1-7/8"	1-7/8"	1-7/8"
	SDR 17	2-1/8"	2"	2-1/8"	2-1/8"	2-1/8"
	SDR 13.5	2-3/8"	2-3/8"	2-1/2"	2-1/2"	2-5/8"
	SDR 11	2-3/4"	2-3/4"	2-7/8"	3"	3"
	SDR 9	3-1/4"	3-1/4"	3-3/8"	3-1/2"	3-5/8"
TAP SIZE 10 (actual size 9-1/2")	SDR 21	2-3/8"	2-1/4"	2-1/4"	2-1/4"	2-1/4"
	SDR 17	2-5/8"	2-1/2"	2-5/8"	2-5/8"	2-5/8"
	SDR 13.5	3"	3"	3"	3"	3"
	SDR 11	3-3/8"	3-3/8"	3-3/8"	3-1/2"	3-1/2"
	SDR 9	3-7/8"	3-7/8"	4"	4"	4"
TAP SIZE 12 (actual size 11-1/2")	SDR 21	3-1/8"	2-7/8"	3"	2-7/8"	2-3/4"
	SDR 17	3-3/8"	3-1/4"	3-1/4"	3-1/8"	3-1/8"
	SDR 13.5	3-3/4"	3-5/8"	3-5/8"	3-5/8"	3-1/2"
	SDR 11	4-1/4"	4-1/8"	4-1/8"	4-1/8"	4"
	SDR 9	4-7/8"	4-5/8"	4-3/4"	4-5/8"	4-3/4"
TAP SIZE 14 (actual size 13-1/2")	SDR 21	4"	3-3/4"	3-3/4"	3-1/2"	3-3/8"
	SDR 17	4-3/8"	4"	4-1/8"	3-7/8"	3-3/4"
	SDR 13.5	4-7/8"	4-1/2"	4-1/2"	4-3/8"	NOTE #7
	SDR 11	5-3/8"	NOTE #7	NOTE #7	NOTE #7	NOTE #7
	SDR 9	NOTE #7	NOTE #7	NOTE #7	NOTE #7	NOTE #7
TAP SIZE 16 (actual size 15-1/2")	SDR 21	5-3/8"	4-7/8"	4-7/8"	4-3/8"	4-1/4"
	SDR 17	5-7/8"	5-1/4"	5-1/4"	4-3/4"	4-5/8"
	SDR 13.5	6-1/2"	5-7/8"	5-3/4"	5-3/8"	NOTE #7
	SDR 11	7-3/8"	NOTE #7	NOTE #7	NOTE #7	NOTE #7
	SDR 9	NOTE #7	NOTE #7	NOTE #7	NOTE #7	NOTE #7
TAP SIZE 18 (actual size 17-1/2")	SDR 21	7-3/8"	6-1/2"	6-3/8"	5-5/8"	5-1/4"
	SDR 17	8-7/8"	7"	6-7/8"	6"	5-5/8"
	SDR 13.5	NOTE #6	8"	7-3/4"	6-3/4"	NOTE #7
	SDR 11	NOTE #6	NOTE #7	NOTE #7	NOTE #7	NOTE #7
	SDR 9	NOTE #7	NOTE #7	NOTE #7	NOTE #7	NOTE #7
TAP SIZE 20 (actual size 19-1/2")	SDR 21	NOTE #6	10-1/8"	9-1/8"	7-1/4"	6-1/2"
	SDR 17	NOTE #6	NOTE #6	NOTE #6	7-7/8"	7"
	SDR 13.5	NOTE #6	NOTE #6	NOTE #6	9"	NOTE #7
	SDR 11	NOTE #6	NOTE #7	NOTE #7	NOTE #7	NOTE #7
	SDR 9	NOTE #7	NOTE #7	NOTE #7	NOTE #7	NOTE #7
TAP SIZE 24 (actual size 22-1/2")	SDR 21	NOTE #6		NOTE #6	9-3/4"	
	SDR 17	NOTE #6		NOTE #6	11-1/4"	
	SDR 13.5	NOTE #6		NOTE #6	NOTE #7	
	SDR 11	NOTE #7		NOTE #7	NOTE #7	
	SDR 9	NOTE #7		NOTE #7	NOTE #7	

REQUIRES USE OF HDPE PILOT
(STANDARD PVC PILOT WILL NOT WORK)

NOTES: STANDARD SIZE CUTTER WILL NOT WORK ~ TOO LARGE FOR ID OF PIPE
NOTE #6 ~ NO CUTTER CURRENTLY AVAILABLE ~

NOTE #7 ~ PIPE WALL THICKNESS TOO MUCH FOR TM-XL PVC PILOT TO CUT THROUGH

NOTE: Tap sizes 14" - 24" apply to TapMate XL only.

Asbestos Cement Pipe												
Nominal Size	4	6	8	10	12	14	16	18	20	24	30	
OD	4.79 - 5.57	7.05 - 7.60	9.22 - 9.79	11.25 - 12.12	13.37 - 14.38	15.36 - 16.88	17.50 - 19.19	20.44 - 22.54	22.50 - 25.02	27.17 - 29.98	33.80 - 37.48	
ID	4 - 3.80	6 - 5.70	8 - 7.60	10 - 9.50	12 - 11.40	14 - 13.30	16 - 15.20	18 - 17.73	20 - 19.70	24 - 23.64	30 - 29.55	
Travel Distance												
Min	1.43	1.09	1.01	0.94	0.95	0.90	0.94	1.39	1.40	1.71	2.00	
Max	2.05	1.55	1.52	1.64	1.77	2.02	2.20	2.58	2.82	3.30	4.07	
Min		2.33	1.71	1.45	1.35	1.24	1.24	1.65	1.64	1.90	2.15	
Max		3.05	2.27	2.19	2.20	2.39	2.51	2.84	3.05	3.49	4.22	
Min			3.22	2.32	2.00	1.77	1.68	2.04	1.98	2.19	2.38	
Max			4.28	3.15	2.90	2.95	2.99	3.24	3.40	3.78	4.45	
Min				4.06	3.02	2.54	2.31	2.58	2.45	2.57	2.67	
Max				6.06	4.04	3.79	3.66	3.79	3.88	4.17	4.75	
Min					4.97	3.69	3.19	3.30	3.07	3.05	3.05	
Max					7.19*	5.10	4.63	4.52	4.51	4.66	5.13	
Min						5.83	4.46	4.27	3.87	3.66	3.51	
Max						8.44*	6.10	5.52	5.34	5.29	5.60	
Min							6.77	5.64	4.93	4.42	4.06	
Max							9.60*	6.97	6.43	6.07	6.16	
Min								8.11	6.41	5.37	4.72	
Max								9.85	7.99	7.04	6.84	
Min									9.03	6.59	5.50	
Max									11.11	8.31	7.64	
Min										9.41	6.98	
Max										11.36	9.16	

* OD of Shell cutter is larger than smallest possible ID of Pipe ~ may not retrieve coupon

NOTE: Tap sizes 14" - 24" apply to TapMate XL only.

