



**Transmate**

**7 HP KOLHER HYDRAULIC POWER UNIT - Rev. 6 04/12/2019**

Thank you for purchasing the Transmate 7HP KOLHER Hydraulic Power Unit. This unit will give you years of service if the simple instructions below are followed. Please read the enclosed Kolher engine manual for engine performance characteristics and maintenance instructions. Also, please read the enclosed information sheet for performance and maintenance information on the hydraulic motor.

The hydraulic power unit converts the power produced by the engine into hydraulic power in the oil. Not only does the oil produce power but also it lubricates all mechanical components in the hydraulic system. Keeping this in mind, the correct selection of hydraulic oil is important for the proper operation and life of this unit. Hydraulic oil should be selected based on ambient outside temperature and number of continuous hours of use per day.

This unit has been used for many years to power the TapMate(tm) drilling machine (350-00), and the Exerciser(tm) (375-00) valve and hydrant exerciser. It is also capable of powering the TapMate Too(tm) (351-00) with the hydraulic drive head attachment (372-351-05).

This power unit has a reservoir size of 2.5 gallons. The power unit has a half duty cycle rating. This means that it can run half an hour per hour. The duty cycle is dependent on the demands made on the unit, so low pressure operation will increase the duty cycle.

**Power unit Specifications:**

- Unit weight - Dry: .....73 lb.
- Unit weight - with fluids full: .....96 lb.
- Maximum pressure: .....2000 psi
- Maximum flow rate: ..... 4 gpm
- Hydraulic oil reservoir size: .....2.5 gallons
- Maximum allowable oil temperature: ..... 180 degrees
- Frame size ..... 18 1/2" wide x 17" tall x 28" long.
- Filler breather hole.....3/4" NPT threaded.
- Quick disconnects ..... Flush Face PN. 372-13-2 (Male)
- ..... and PN. 372-13-3 (Female)

**Output torque and speed of various drive motors:**

Drive head	Part Number	Maximum Speed	Maximum torque
TapMate(tm) drive head and hoses	372-05	72 rpm	253 ft. lbs.
The Exerciser(tm)	375-00	60 rpm	320 ft. lbs.
TapMate Too(tm) drive head and hoses	372-351-05	230 rpm	84 ft. lbs.

**This unit is equipped with the following items:**

- Sturdy aluminum frame that encloses the entire power unit. (18 1/2" x 17" x 28")
- Easy starting 7 HP Kolher overhead valve engine.
- Recoil cord pull start engine.  
Electric start engine with 15 amp. charging system is optional (372-991).
- 2.5-gallon hydraulic reservoir.
- Sight and Temperature gauge easily seen by the user.
- Reservoir drain hole on the bottom for easy changing of the hydraulic oil.
- Totally enclosed pump for protection and elimination of reservoir to pump hoses and tubing.
- Oil by-pass system at base unit for easy starting and hose connection.

## Operating Instructions:

1. Fill hydraulic oil reservoir to one (1) inch from the top with hydraulic oil. As you fill the reservoir check the sight and temperature gauge on the side of the unit for oil level. See Fluids - Hydraulic oil specifications below. Over filling the reservoir will result in oil flowing out the filler breather cap when the oil gets warm.
2. Check engine oil and fill as needed. See Fluids - Engine Oil specifications.
3. Check and fill gasoline tank if needed. See Fluids - Gasoline specifications.
4. Identify the pressure out port and the return port. The pressure port has a "P OUT" label stamped near it and a male quick disconnect usually pointing vertical threaded into it. The return port points outward to the side of the by-pass valve and has a female quick disconnect threaded into it.
5. Hook the pressure hose to the pressure port and the return hose to the return port. The hoses don't need to be hooked up to start the engine.
6. In the event the hoses cannot be hooked up please position the by pass valve to "Tool off", "off", or "open". Once the unit is running connect the return hose then the pressure hose. Position the by pass valve to "Tool on", "on", or "closed" when oil flow is needed.
7. Position the choke to full.
8. Position the throttle lever to half throttle.
9. Pull the recoil start cord until the unit starts.
10. When the engine starts, slowly adjust the choke until the engine is running smoothly. Once the engine is warmed up turn the choke off.
11. Position the throttle to "fast" as indicated.

## Maintenance Instructions:

1. Read engine manual for proper maintenance schedule.
2. Change hydraulic oil every 3 - 12 months depending upon use.

## Fluids:

1. **Gasoline**  
Regular unleaded with an octane rating of 87 or higher.
2. **Hydraulic oil**  
High quality oil ISO VG 32-68  
Shell Tellus T 32 - 68 or equivalent

As outside temperature conditions vary so widely please consult your hydraulic oil distributor or manufacturer for proper hydraulic oil selection. It is important to use the proper oil that matches the temperature conditions. Premature failure of the equipment can result if the proper oil is not used.

3. **Engine Oil:**  
High quality oil 10w - 30 or 10W - 40 only.

## Common problems:

- |  |  |
|--|--|
| 1. Engine will not start.                          | Check gas tank, turn on gas valve.<br>Connect hoses to unit or position bypass valve to off. |
| 2. Pump developing flow but no pressure            | Call Transmate at 1 800-426-9341.  |
| 3. Hydraulic oil is milky white                    | Change hydraulic fluid immediately, it has been contaminated with water                      |
| 4. Hydraulic motor rotating in the wrong direction | Hoses are connected backwards.   |

372-01-10, HD, MULTI-PURPOSE 7HP HYDRAULICS ONLY

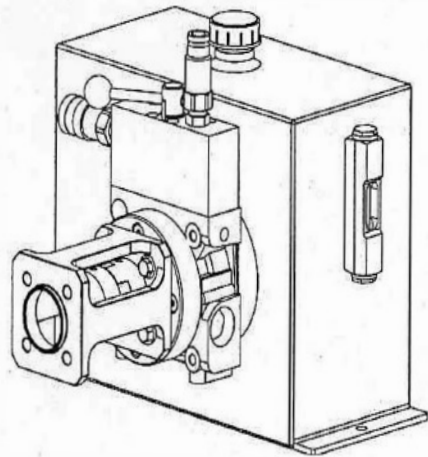

372-01-1001,  
HD, 7HP HYD PUMP  
& BY-PASS ASSY

372-40 HD, FILLER BREATHER CAP

372-01-02-04,  
HD, 7HP C-FACE  
ALUMINUM ADAPTER

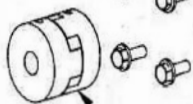
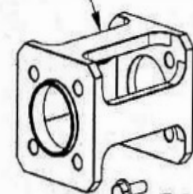

372-L095-5-75,  
HD, FLEXIBLE DRIVE COUPLING

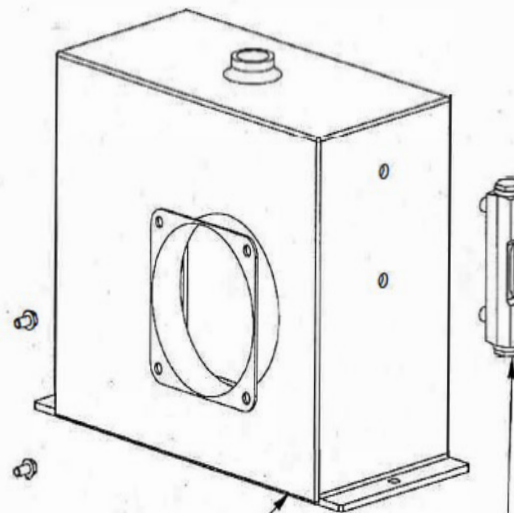

372-2281133,  
HD RESERVOIR

372-2510041  
HD, ENGINE 7HP, SIGHT GLASS

# 372-01-1001, HD, 7HP HYD PUMP & BY-PASS ASSY

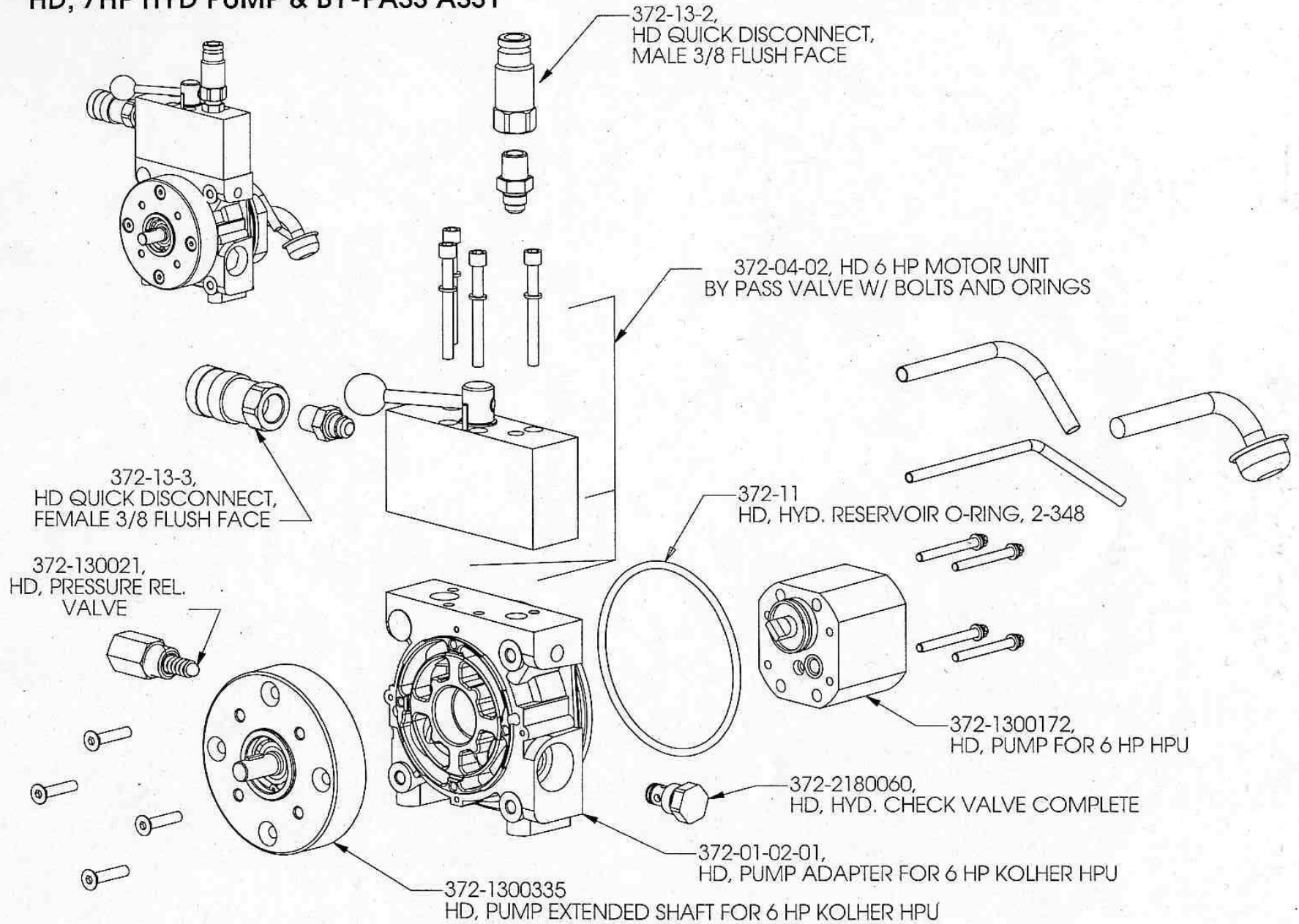

## 372-02 HD 3/8 IN. HOSE KIT

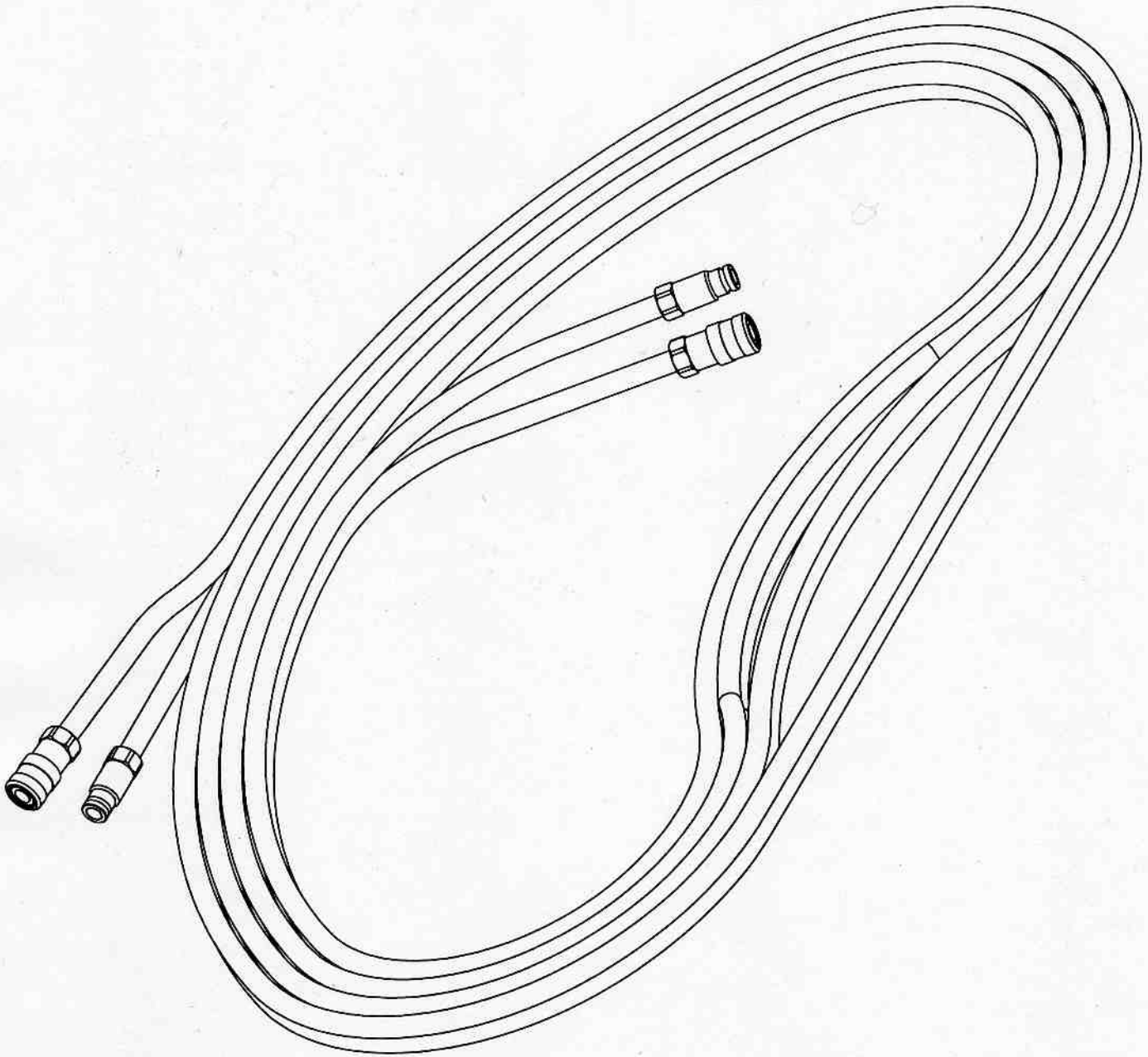

372-02-02	HD HYDRAULIC HOSE 3/8 x 20 FT.	QTY 2
372-13-2	HD QUICK DISCONNECT, MALE 3/8 FLUSH FACE	QTY 2
372-13-3	HD QUICK DISCONNECT, FEMALE 3/8 FLUSH FACE	QTY 2

# HD TAPMATE HYDRAULIC MOTOR & BY-PASS VALVE ASSEMBLY 372-05-02

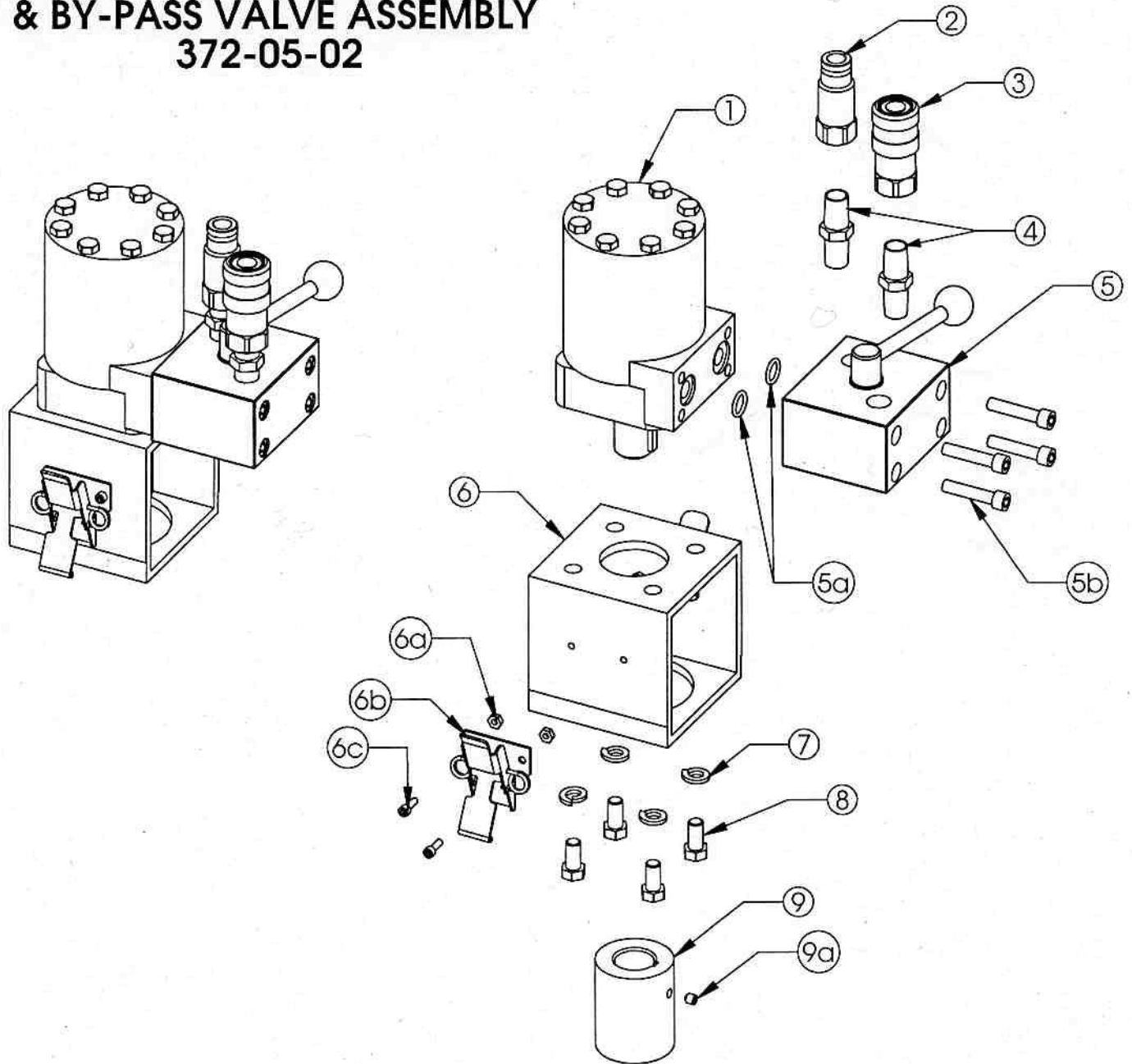

- |     |           |  |
|-----|-----------|--|
| 1)  | 372-05-12 | HD HYDRAULIC MOTOR ONLY 14.1 OR 13.9 CU. IN.                         |
| 2)  | 372-13-2  | HD QUICK DISCONNECT, MALE 3/8 FLUSH FACE FF372-6FP                   |
| 3)  | 372-13-3  | HD QUICK DISCONNECT, FEMALE 3/8 FLUSH FACE FF371-6FP                 |
| 4)  | 372-13-11 | HD 3/8 IN. X 3/8 IN. NPT HYD. NIPPLE WEATHERHEAD #C3069 X 6          |
| 5)  | 372-04    | HD BY PASS VALVE ONLY W/ BOLTS AND ORINGS                            |
| 5a) |           | ERIKS O-RING, # 2-112 (QTY 2)  |
| 5b) |           | 5/16"-18 x 3 1/4" Lg. SHCS (QTY 4)                                   |
| 6)  | 372-80    | HD HYDRAULIC DRIVE ADAPTER (Complete w/ 6a, 6b, & 6c)                |
| 6a) | 372-06-01 | HD HYDRAULIC ADAPTER LATCH (2 REQ. PER ADAPTER)                      |
| 6b) | 372-09-01 | HD HYDRAULIC ADAPTER LATCH BOLT (2 REQ. PER LATCH) 8-32              |
| 6c) | 372-09-02 | HD HYDRAULIC ADAPTER LATCH NUT (2 REQ. PER LATCH) 8-32               |
| 7)  | 372-10    | HD HYDRAULIC ADAPTER BOLT 3/8-16 X 3/4 IN. LONG H.H.C.S. ZINC PLATED |
| 8)  | 372-07    | HD HYDRAULIC LOCK WASHER 3/8 IN.                                     |
| 9)  | 372-81    | HD HYDRAULIC DRIVE COUPLING (Includes 9a)                            |
| 9a) | 351-51-2  | TT, ARBORS & HANDLE SET SCREW, 1/4-20 X 1/4                          |