

# INSTALLATION INSTRUCTIONS

Read installation instructions first before installing. Check parts to ensure that no damage has occurred during transit and that no parts are missing. Also check the diameter of the pipe and the range marked on the clamp to ensure you have the proper size.

## Style SC Repair Clamp

**Step 1** • Check the Clamp parts to insure that no damage has occurred during transit and that no parts are missing. Also check the diameter of the pipe and the size marked on the clamp to insure you have the proper size. Thoroughly clean pipe surface that will be covered by the clamp. A suitable gasket lubricant should be used on rough surface pipe (Iron and A/C) to assure proper seal.

**Step 2** • Place reference marks on the pipe in line with the crack or hole in the pipe, slightly wider than the clamp.

**Step 3** • Back off nuts to the end of the bolt – **DO NOT REMOVE**. Separate clamp and wrap it around the pipe, positioning it so the bolts are in a convenient place for assembly and tightening.

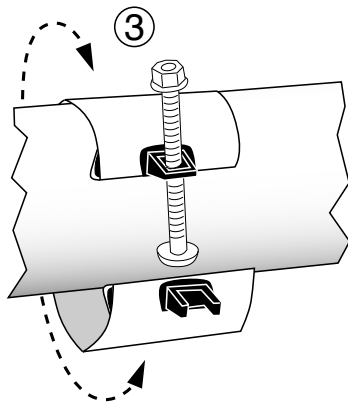

**Step 4** • Pull clamp ends together and snap bolt head into receiver lug. Make sure the gasket has seated itself flat onto the pipe face. Tighten nuts finger tight. Rotate clamp into position and center the clamp over the crack or hole being repaired (check reference marks).

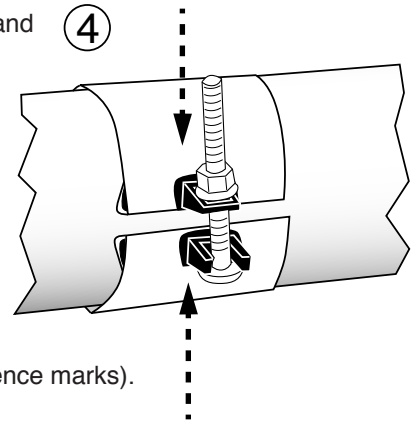

**Step 5** • Starting in the center and working towards each end, tighten all nuts evenly in 20 ft-lb. increments. Keep torques as evenly balanced as possible. Use a wrench with at least a 12" handle.

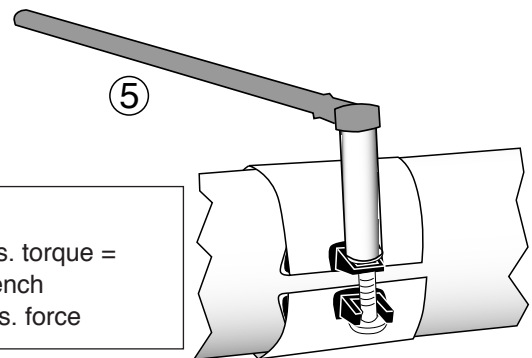

**Note:**  
25 ft-lbs. torque =  
12" wrench  
w/25 lbs. force

Nom. Pipe Diameter	Torque
Below 3"	20-25 ft-lbs.
3" - 8"	40-45 ft-lbs.

For best results, wait 10 minutes and then re-tighten to proper torque.

**Note:** If necessary (because of water pressure) Step 4 and Step 5 can be performed beside the pipe break. Slide the clamp over the break after the bolts have been snapped in place.

## Repair Clamp Style SC

### PRECAUTIONS

1. Check diameter of pipe to make sure you are using the correct size clamp.
2. Clean pipe to remove dirt and corrosion from the surface.
3. Place marks on the pipe to reference the leak. Use these marks to assure that the clamp is properly positioned.
4. Make sure no foreign materials stick to the gasket as it is brought around the pipe, nor become lodged between gasket and pipe as nuts are tightened.
5. Avoid loose fitting wrenches, or wrenches too short to achieve proper torque.
6. Keep threads free of foreign material to facilitate tightening.
7. Bolts are often not tightened enough when a torque wrench is not used. Take extra care in this situation to make sure proper tightening occurs.
8. Pressure test for leaks before backfilling.
9. Backfill and compact carefully around clamp.
10. When reinstalling parts with stainless steel hardware there may be a loss in pressure holding ability due to worn or damaged threads during the original installation.

### COMMON INSTALLATION PROBLEMS

1. Bolts are not tightened to the proper torque.
2. Rocks or debris between pipe and gasket.
3. Dirt on threads of bolts or nuts.
4. Repair clamp too small for the size of damage to pipe.
5. Repair clamp not centered over damaged portion of pipe.
6. Repair clamps should not be used as couplings.
7. If bolts are not able to be fully seated, tighten one side until the second side can be fully seated. Then loosen the first side to fully seat the bolt and continue per install directions.
8. For more help, see SCC Installation TROUBLESHOOTING video at [romac.com/screpairclamp](http://romac.com/screpairclamp)