

INSTALLATION INSTRUCTIONS

Read installation instructions first before installing. Check parts to ensure that no damage has occurred during transit and that no parts are missing. Also check the diameter of the pipe and the size marked on the coupling to ensure you have the proper size.



RFCA Restrained Flange Coupling Adapter

For use on: Ductile iron pipe 3" - 24", cast iron pipe 3" - 24" (same OD's as ductile iron), IPS size steel 3" - 12" with a minimum thickness per ASTM A53 std. weight class pipe.

NOTE: Not for use on polyethylene pipe, plain end mechanical joint fittings or PVC pipe.

The "Stab-Fit" installation technique may also be employed on 3"-10" sizes.

Step 1 • Check the RFCA parts to insure that no damage has occurred during transit and that no parts are missing.

Step 2 • Clean pipe end for a distance of 2" greater than length of the RFCA.

Step 3 • Place RomaGrip gland on pipe end.

Step 4 • Lubricate the gasket and pipe surface with soapy water or other suitable gasket lubricant.

Step 5 • Place gasket over pipe with beveled edge toward the flange adapter.

Step 6 • Slide the RFCA on to the pipe. Position the pipe and flanged coupling against the mating flange. Assemble the flange joint using flange bolts. A minimum of 1" pipe insertion beyond gasket is required.

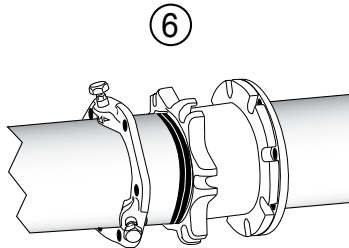

Step 7 • The pipe should be centered such that the space between the OD of the pipe and the ID of the RFCA is even all around the pipe. Slide the RFCA gasket into position with the beveled edge engaging the beveled end of the RFCA body.

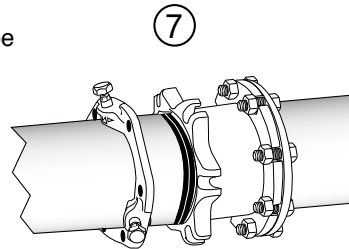

Step 8 • Slide the RomaGrip into position against the gasket, and insert T-bolts.

When stainless steel fasteners are requested, Romac provides all-thread-rod and two nuts. The underside of the lug on the RFCA body is designed to capture hex nuts as well as "T" head bolts.

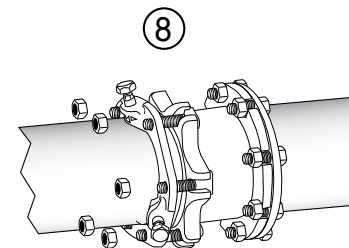

Step 9 • Tighten T-bolts evenly, alternating to diametrically opposite position at approximately 20 ft-lbs increments to the recommended torque for your size RFCA.

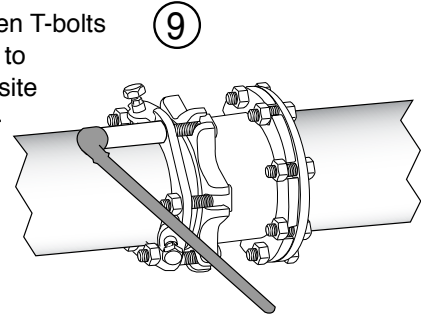

Recommended Torque:

- 3" RomaGrip - 45-65 ft-lbs.
- 4 - 24" RomaGrip - 75 - 90 ft-lbs.

Note:

90 ft-lbs. torque = 12" wrench w/90 lbs. force

For best results, wait 10 minutes and retighten bolts to proper torque.

Step 10 • Hand tighten the restrainer bolts until the restraining pads touch the surface of the pipe. The bolts should be tightened in a uniform criss-cross pattern, until the heads break off above the notch.

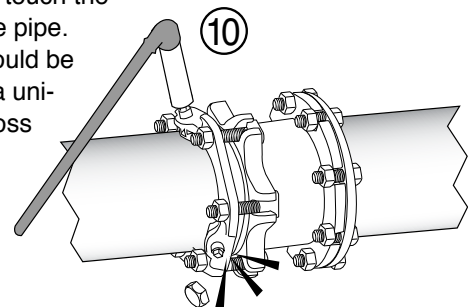

NOTE: Do not turn a bolt more than one turn before alternating to the next bolt.

Step 11 • Pressure test for leaks before backfilling.

RFCA Restrained Flange Coupling Adapter

PRECAUTIONS

1. Check flange to make sure the bolt holes match the RFCA.
2. Check diameter of pipe to make sure you are using the correct size RFCA.
3. Be sure to clean pipe of as much dirt and corrosion as possible in the area that the gasket will seal.
4. Lubricate both the gasket and the pipe end with soapy water or approved pipe lubricant per ANSI/AWWA C111/A21.11.
5. Make sure no foreign materials lodge between gasket and pipe.
6. Avoid loose fitting wrenches, or wrenches too short to achieve proper torque.
7. Keep threads free of foreign material to allow proper tightening.
8. Take extra care to follow proper bolt tightening procedures and torque recommendations. Bolts are often not tightened enough when a torque wrench is not used.
9. Be sure that the gland is centered around the pipe.
10. Pressure test for leaks before backfilling.
11. Backfill and compact carefully around pipe and fittings.
12. Some initial axial movement may occur in lug style restraints as the lugs seat. Movement is directly related to the size of the piping system and the system pressure. In general terms movement of approximately 0.25" can be expected in restraints under 16". For larger sizes, movement of approximately 0.4" may be seen. If this is critical to your application please contact Romac Engineering for additional information.

COMMON INSTALLATION PROBLEMS

1. Flange gasket installed over existing o-ring gasket.
2. T-Bolts are not tightened to the proper torque.
3. Rocks or debris between pipe and gasket.
4. Dirt or debris between pipe and restraining pad.
5. Dirt on threads of bolts or nuts.
6. Restraining bolt heads not snapped off.
7. Not enough pipe inserted into bell.
8. Using the RFCA on IPS size steel pipe with wall thickness thinner than schedule 40 steel pipe. (3-12 inch sizes)

IF RFCA MUST BE REMOVED

1. Make sure pipe is not pressurized. Removing the restrainer could cause the pipe joint to separate.
2. To remove the RFCA, use a $\frac{5}{8}$ " hex wrench or socket.
3. To reassemble, follow installation procedures. Tighten the restraining bolts using a $\frac{5}{8}$ " hex wrench to 75-ft-lbs minimum.