

INSTALLATION INSTRUCTIONS

Read installation instructions first before installing. Check parts to ensure that no damage has occurred during transit and that no parts are missing. Also check the diameter of the pipe and the range marked on the coupling to ensure you have the proper size.

FCG Flange Coupling Adapter

Step 1 • Check the FCG parts to insure that no damage has occurred during transit and that no parts are missing.

Step 2 • Clean pipe end for a distance of 2" greater than length of the FCG.

Step 3 • Place FCG gland on pipe end.

Step 4 • Lubricate the gasket and pipe surface with soapy water or other suitable gasket lubricant.

Step 5 • Place gasket over pipe with beveled edge toward the end of the pipe.

Step 6 • Slide the FCG on to the pipe. Position the pipe and flanged coupling against the mating flange. Assemble the flange joint using flange bolts (not provided).

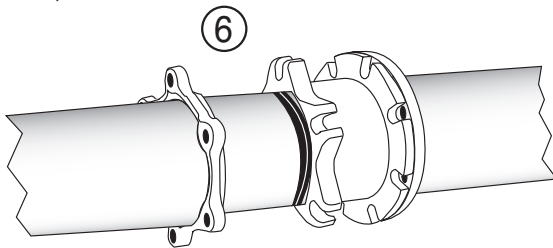

Step 7 • The pipe should be centered such that the space between the OD of the pipe and the ID of the FCG is even all around the pipe. Slide the FCG gasket into position with the beveled edge engaging the beveled end of the FCG body.

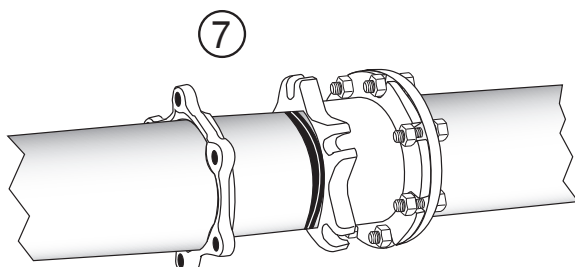

Step 8 • Slide the FCG Gland into position against the gasket, and insert T-bolts.

When stainless steel fasteners are requested, Romac provides all-thread-rod and two nuts. The underside of the lug on the FCG body is designed to capture hex nuts as well as "T" head bolts.

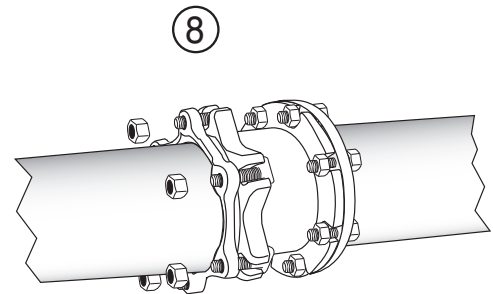

Step 9 • Tighten T-bolts evenly, alternating to diametrically opposite position at approximately 20 ft-lbs increments to the recommended torque for your size FCG.

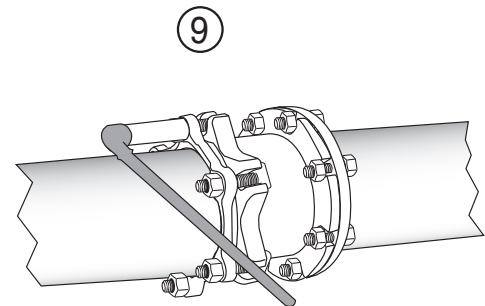

Recommended Torque:

3" FCG - 45-65 ft-lbs.
4 - 12" FCG - 75 - 90 ft-lbs.

Note:

90 ft-lbs. torque = 12" wrench w/90 lbs. force

For best results, wait 10 minutes and retighten bolts to proper torque.

Step 10 • Pressure test for leaks before backfilling.



FCG Flange Coupling Adapter

PRECAUTIONS

1. Check flange to make sure the bolt holes match the FCG.
2. Check diameter of pipe to make sure you are using the correct size FCG; also check gasket to make sure it is the size you think it is.
3. Be sure to clean pipe of as much dirt and corrosion as possible in the area that the gasket will seal.
4. Lubricate both the gasket and the pipe end with soapy water or approved pipe lubricant per ANSI/AWWA C111/A21.11.
5. Make sure no foreign materials lodge between gasket and pipe.
6. Avoid loose fitting wrenches, or wrenches too short to achieve proper torque.
7. Keep threads free of foreign material to allow proper tightening.
8. Take extra care to follow proper bolt tightening procedures and torque recommendations. Bolts are often not tightened enough when a torque wrench is not used.
9. Be sure that the gland is centered around the pipe.
10. Pressure test for leaks before backfilling.
11. Backfill and compact carefully around pipe and fittings.

COMMON INSTALLATION PROBLEMS

1. T-Bolts are not tightened to the proper torque.
2. Rocks or debris between pipe and gasket.
3. Dirt on threads of bolts or nuts.
4. Not enough pipe inserted into FCG body.