

INSTALLATION INSTRUCTIONS

Read installation instructions first before installing. Check parts to ensure that no damage has occurred during transit and that no parts are missing. Also check the diameter of the pipe and the range marked on the clamp to ensure you have the proper size.

Style CL1, CL2 & CL3 Cast-Lug Pipe Repair Clamps (Hinged)

Step 1 • Check the clamp parts to insure that no damage has occurred during transit and that no parts are missing. Thoroughly clean pipe surface that will be covered by the clamp. A suitable gasket lubricant should be used on rough surfaced pipe (Iron and A/C) to assure proper seal.

Step 2 • Place reference marks on the pipe in line with the crack or hole in the pipe, slightly wider than the clamp.

If using tapped repair clamp, be sure that the outlet is positioned in the area where the tap is to be done.

Step 3 • Back off nuts to end of bolts, but **DO NOT REMOVE THEM**. On clamps with more than one section, one row of bolts has open lugs, which allow the bolt heads to come out, and the clamp to open. The other row(s) of bolts act as a hinge.

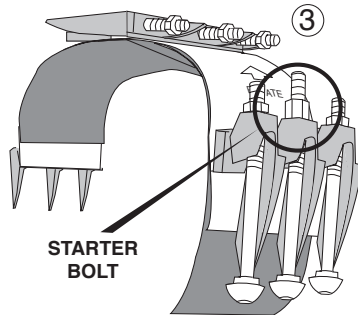

Step 4 • Wrap the clamp around the pipe and snap the starter bolt head(s) into the open lug(s). Tighten until the other bolts can be snapped into the lugs.

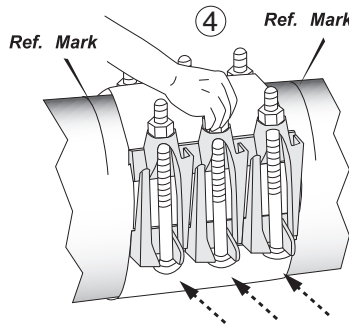

NOTE: If necessary (because of water pressure), Step 3 and Step 4 can be performed beside the pipe damage. Slide the clamp over the damage after the bolt heads have been snapped in place.

Step 5 • Make sure the tails are properly overlapped, and are not folded. Clamp may be rotated to facilitate seating of the tails. See directional arrow on clamp. Center one of the sections over the crack or hole being repaired (check reference marks).

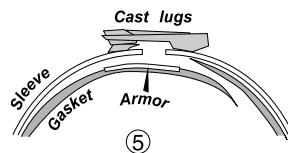

Step 6 • Begin by tightening the center bolt, and work toward each end, tightening all nuts evenly in 20 ft-lb. increments. On clamps with more than one section, maintain equal gaps between sections, keeping torques as evenly balanced as possible. Use a wrench with at least a 12" handle.

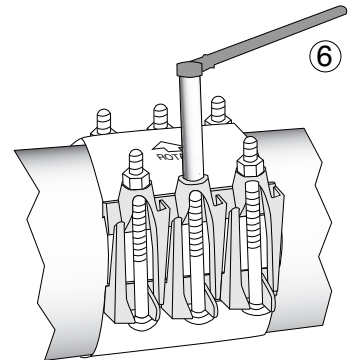

Note:

35 ft-lbs. = 12" wrench w/ 35 lb. force
75 ft-lbs. = 12" wrench w/ 75 lb. force

Nom. Pipe Diameter	Torque
4" and below	35-45 ft-lbs.
6" and above	75-85 ft-lbs.

For best results, wait 10 minutes and then retighten to proper torque.

If using tapped repair clamp, pressure test before tapping.

Backfill and compact carefully around clamp and service line.

If the lugs need to be removed, remove the bolts, and locate the coining on the lug. Using a hammer, tap the lug in the direction of the coining until it falls off.

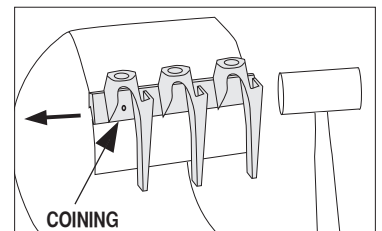

If your clamp has multiple lugs, tap the end lugs off first (see illustration). The lugs in the middle won't have coining and should slide off without using a hammer.

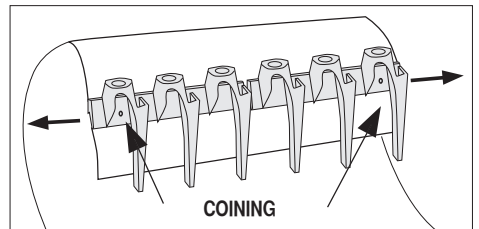

Style CL1, CL2 & CL3 Cast-Lug Pipe Repair Clamps (Hinged)

PRECAUTIONS

1. Check diameter of pipe to make sure you are using the correct size clamp.
2. Clean pipe to remove dirt and corrosion from the surface.
3. Place marks on the pipe to reference the leak. Use these marks to assure that the clamp is properly positioned.
4. Make sure no foreign materials stick to the gasket as it is brought around the pipe, nor become lodged between gasket and pipe as nuts are tightened.
5. Avoid loose fitting wrenches, or wrenches too short to achieve proper torque.
6. Keep threads free of foreign material to facilitate tightening.
7. Bolts are often not tightened enough when a torque wrench is not used. Take extra care in this situation to make sure proper tightening occurs.
8. Pressure test for leaks before backfilling.
9. Backfill and compact carefully around clamp.
10. When reinstalling parts with stainless steel hardware there may be a loss in pressure holding ability due to worn or damaged threads during the original installation.

COMMON INSTALLATION PROBLEMS

1. Bolts are not tightened to the proper torque.
2. Rocks or debris between pipe and gasket.
3. Dirt on threads of bolts or nuts.
4. Repair clamp too small for the size of damage to pipe.
5. Repair clamp not centered over damaged portion of pipe.
6. Repair clamps should not be used as couplings.
7. Gaps between sections are not equal.
8. Gasket tails bunched.
9. Not using proper lubrication.