

INSTALLATION INSTRUCTIONS

Read installation instructions first before installing. Check parts to ensure that no damage has occurred during transit, the bolt guides are aligned with the axis of the pipe, and no parts are missing.

Certified to NSF/ANSI/CAN 61

Alpha 45™

Restrained Fitting Sizes 8x8, 10x10 & 12x12

When properly installed, ALPHA can be used at working pressures equal to the lesser of 350 psi, pipe rating, or value listed below:

PIPE MATERIAL	SIZE	WORKING PRESSURE
Ductile Iron	4-12"	350 psi
PVC, IPS size	4-12"	350 psi
PVC, DI size	4-12"	350 psi
C909	4-6"	235 psi
C909	8-12"	150 psi
HDPE: SDR 9, 11, 13.5 & 17*	4-12"	rating of pipe

* For SDRs greater than 17, pipe stiffeners are required.
For other SDR's and pipe materials, contact Romac.

ALPHA RANGES

STANDARD ALPHA: For IPS through DI sized pipe diameters.

SIZE	STANDARD ALPHA
4"	4.50 - 4.90
6"	6.60 - 7.00
8"	8.60 - 9.10
10"	10.75 - 11.20
12"	12.75 - 13.30

Step 1 • Measure pipe diameter and verify with the ranges listed above to ensure the correct size fitting has been selected.

Step 2 • Remove any scale or debris that could interfere with gripper engagement of the pipe. Clean the pipe surface wherever the gasket will come in contact with the pipe, and check to see that the pipe surface is smooth (no dents, projections, gouges, etc.) where the gasket seals against the pipe.

Step 3 • Mark the pipe at the minimum insertion depth.

SIZE	Distance from end of pipe
8"	5.00
10"	5.00
12"	6.00

Step 4 • Lubricate the gasket and pipe surface with a suitable gasket lubricant.

Step 5 • With the bolt in the extended position, place the fitting onto the plain pipe end until the pipe bottoms out on the casting or the minimum insertion depth is reached. For installation on HDPE, pipe ends should be butted against the casting.

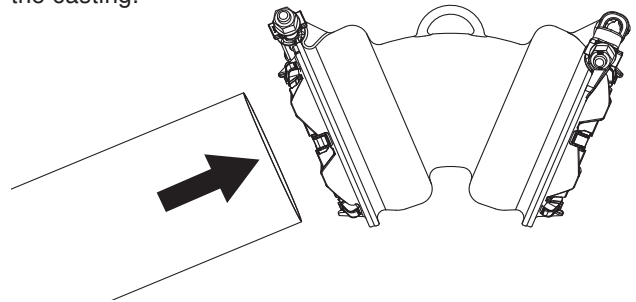

Step 6 • Set the desired pipe deflection. **Note:** Do not deflect pipe joint after installation.

Std. Alpha
Maximum deflection:
4 degrees

Step 7 • Bring the other pipe into position repeating steps 1-6. Be sure to maintain proper pipe insertion for all joints.

Step 8 • Tighten all nuts to 45 ft-lbs. using a torque wrench.

TORQUE
45 ft-lbs.
DO NOT OVERTORQUE

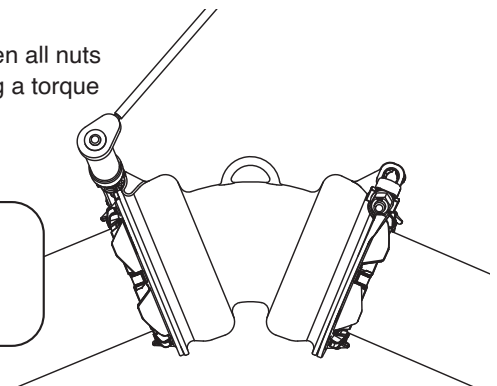

NOTE: Do not use an impact wrench. Do not overtorque, or retighten. If a good seal is not achieved at the installation torque, refer to the Common Installation Problem listed on side two.

Step 9 • Confirm proper installation by pressurizing the line and checking for leaks.

Step 10 • Backfill and compact carefully around pipe and fitting.

Alpha 45™

Restrained Fitting
Sizes 8x8, 10x10 & 12x12

PRECAUTIONS

1. Check diameter of pipe to make sure the correct sized fitting has been selected.
2. Confirm the pipe is round. The fitting may not fit or function on pipe that is too far out of round.
3. Clean pipe to remove dirt and corrosion from pipe surface. Use appropriate scale removal tools where appropriate to assure all scale and debris is properly removed.
4. Lubrication and additional cleaning should be provided by brushing both the gasket and plain pipe end with soapy water or approved pipe lubricant per ANSI/AWWA C111/A21.11.
5. Make sure no foreign materials lodge between gasket and pipe, between the grippers or in the end ring mechanism.
6. Avoid loose fitting wrenches, or wrenches too short to achieve proper torque.
7. Keep threads free of foreign material to allow proper tightening.
8. For cold weather conditions (below 40° F), performance can be improved by warming up the fitting and gasket.
9. Verify that the grippers are in contact with the pipe surface.
10. Do not strike or pry on the fitting with hammers, shovels or other equipment.
11. When reinstalling, prior to pressure applications, be sure to inspect all parts for damage.
12. If it's necessary to remove Alpha, loosen the bolt and tap the end ring bolt receiver open. Tapping the hooks into their notches may also be required. To assist removal, rotate fitting body back and forth while pulling.
13. Do not reuse the fitting after pressure application.
14. It is common for the bolt receivers to meet on installations at the bottom of the range.
15. Directional drilling requires special consideration prior to installation. Contact Romac Engineering for any directional drilling applications.
16. Romac mechanical restraint products are designed and tested to provide axial load restraint as specified. System design must be such that the restraint is only exposed to this type of loading. Special consideration may be required for above ground installations where the alignment and support benefits of earth are not present.

PRECAUTIONS FOR HDPE PIPE

1. Alpha working pressure not to exceed pressure rating of pipe.
2. For SDR's greater than 17, pipe stiffeners are required.
3. Operating temperatures are limited to 85° F maximum and 32° F minimum.
4. Recommended for buried applications only. For above ground use, contact Romac Engineering.

COMMON INSTALLATION PROBLEMS

1. Pipe not inserted into the fitting far enough.
2. Too much pipe deflection.
3. Damage to the outer pipe surface (dents, projections, gouges, etc.)
4. Bolts not tightened to proper torque.
5. Fasteners partially tightened down making pipe insertion difficult. Remove yellow thread caps and back nuts off before insertion.