

# INSTALLATION INSTRUCTIONS

Read installation instructions first before installing. Check parts to ensure that no damage has occurred during transit and that no parts are missing. Also check the diameter of the pipe and the range marked on the clamp to ensure you have the proper size.

## Style 517 Bell Joint Leak Clamp

517 Bell Joint Leak Clamps for 10" & 12" Class 200 pipe require special gasket

**Step 1** • Check the BJLC parts to insure that no damage has occurred during transit. Clean all around the pipe and on the face of the bell where the gasket will contact. These surfaces must be free of all dirt, etc.

**Step 2** • Wrap the gasket around the pipe with the thick edge of the gasket toward the bell. The gasket ends should meet so that the puzzle joints interlocks, holding the ends of the gasket together. Lubricate the gasket with a suitable gasket lubricant. The joint in the gasket should be 90° from the joint in the pipe ring.

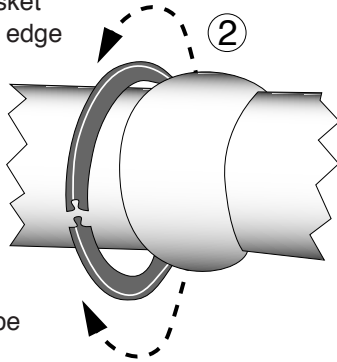

**Step 3** • Assemble one ring around the pipe, (it may be necessary to insert one bolt with nuts to hold ring segments together) push the assembled ring and gasket against the face of the pipe bell.

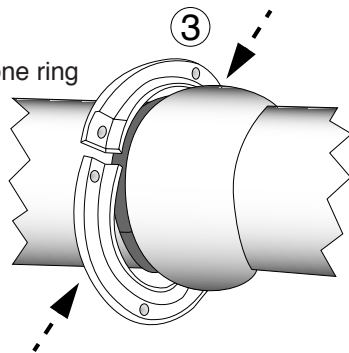

**Step 4** • Assemble the other ring around the pipe behind the bell. Insert bolts and hand tighten all nuts. 10" and 12" come with flat washers.

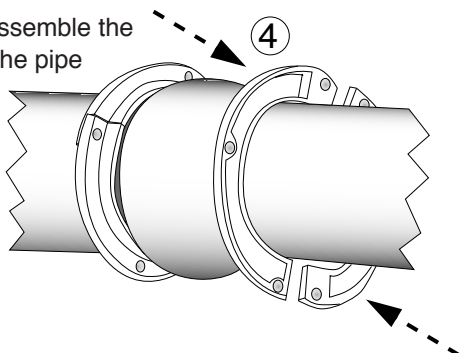

**Step 5** • Make certain the gasket is under the packing ring as shown in the sketch.

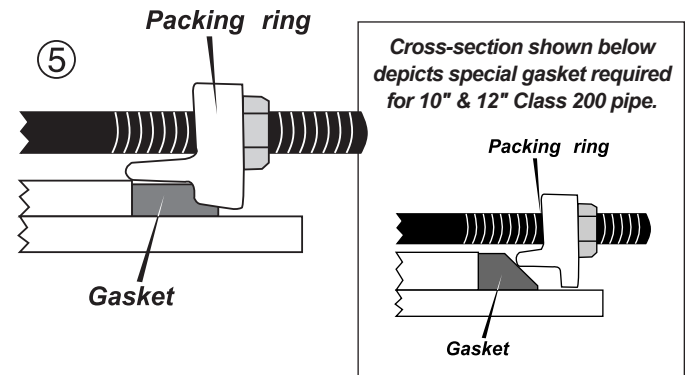

**Step 6** • Tighten bolts evenly around the pipe in 15 ft-lbs increments.

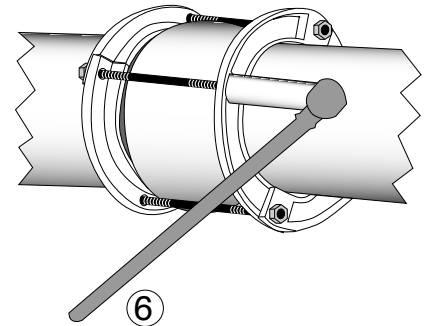

Nom. Pipe Size	Torque
4"-8"	35-45ft.-lbs.
10"-12"	50 - 60 ft-lbs

**Note:**  
 45 ft-lbs. torque = 12" wrench w/45 lbs. force  
 60 ft-lbs. torque = 12" wrench w/60 lbs. force

For best results, wait 10 minutes and re-torque.

**Step 7** • Check for leaking. Re-tighten the bolts evenly around the pipe as necessary to stop leaking.

## Style 517 Bell Joint Leak Clamp

517 Bell Joint Leak Clamps for 10" & 12" Class 200 pipe require special gasket

### PRECAUTIONS

1. Check diameter of pipe to make sure you are using the correct size clamp; also check gasket to make sure it is the size you think it is.
2. Clean pipe to remove as much dirt and corrosion as possible from pipe surface and bell face where the gasket will contact. Lubricate gasket and pipe with soapy water or approved pipe lubricant per ANSI/AWWA C111/A21.11.
3. Make sure no foreign materials lodge between gasket and pipe.
4. Avoid loose fitting wrenches, or wrenches too short to achieve proper torque.
5. Keep threads free of foreign material to allow proper tightening.
6. Take extra care to follow proper bolt tightening procedures and torque recommendations. Bolts are often not tightened enough when a torque wrench is not used.
7. The thick edge of the gasket should be facing the bell face.
8. The puzzle joint of the gasket should be between casting joints.
9. Pressure test for leaks before backfilling.
10. Backfill and compact carefully around pipe and fitting.
11. When reinstalling parts with stainless steel hardware there may be a loss in pressure holding ability due to worn or damaged threads during the original installation.

### COMMON INSTALLATION PROBLEMS

1. Bolts are not tightened to the proper torque.
2. Rocks or debris between pipe and gasket.
3. Dirt on threads of bolts or nuts.
4. Puzzle joint in gasket not off set from casting joint.
5. Thick end of gasket not toward the bell face.
6. Too much pipe deflection.
7. Using wrong gasket (a special gasket is required for 10" & 12" Class 200 pipe).