



STS420 STAINLESS STEEL TAPPING SLEEVE

MATERIAL SPECIFICATIONS

BODY AND OUTLET: Stainless steel, thick gauge ASTM A240 type 304/304L or equal. Chemically passivated after welding for maximum corrosion resistance. Type 316 stainless steel is optional.

BOLTS AND NUTS: Trackhead bolts, heavy hex nuts, 5/8" UNC rolled thread, type 304 SS. Nuts coated to prevent galling.

OUTLET GASKETS: SBR per ASTM D2000, compounded for water and sewer service use. For 3" - 12" size-on-size flanges, the gaskets are reinforced with a metal ring. Larger than 12" size-on-size sleeves use a square profile o-ring NBR per ASTM D2000 set in a full body thickness cavity. Other compounds available on request.

TEST PLUG: 3/4" NPT type 304 stainless steel test plug.

FLANGE GASKETS: 3" - 12" full face proprietary gasket are made from Styrene Butadiene Rubber (SBR) compounded for water and sewer service in accordance with ASTM D2000. Other compounds available for petroleum, chemicals or high temperature service.

FLANGE: Stainless steel, ASTM A240 type 304 per AWWA C228 class "D" plate flange, ANSI class 150 drilling, proper recessing for tapping valves. Will accommodate tapping flanges per MSS SP-60.

Meets requirements of MSS SP-124.

USE: The STS420 Stainless Steel Tapping Sleeve is used to make a branch outlet from a main supply line on most types of pipe (except for reinforced concrete cylinder pipe).

NOTE: STS420 is designed for rigid pipe. It is not recommended for thin or brittle pipe such as high DR C900, IPS PVC, PIP, SDR35. For these applications see SST or FTS419 product pages.



NSF61 certified upon request.

Certified to NSF/ANSI 61 & 372

FLANGE SIZE	A	B	C	D	BOLTS QTY: SIZE
3"	12"	5.18"	4.03"	3.26"	8: 5/8" x 7"
4"	12"	5.18"	5.03"	4.79"	8: 5/8" x 7"
6"	12"	5.18"	7.03"	6.79"	8: 5/8" x 7"
8"	16"	5.18"	9.03"	8.79"	10: 5/8" x 7"
10"	20"	5.50"	11.03"	10.79"	14: 5/8" x 7"
12"	20"	5.75"	13.03"	12.79"	14: 5/8" x 7"
14"¹	24"	6.00"	15.03"	14.79"	16: 5/8" x 7"
16"¹	30"	6.00"	17.03"	16.79"	20: 5/8" x 7"
18"¹	30"	6.00"	19.03"	18.79"	20: 5/8" x 7"
20"¹	36"	6.00"	21.03"	20.73"	24: 5/8" x 7"
24"¹	48"	6.63"	25.03"	24.73"	32: 5/8" x 7"

¹NOTE: Tapping valve manufacturer must be specified.

ALSO AVAILABLE WITH THREADED OUTLET MODEL STS420T

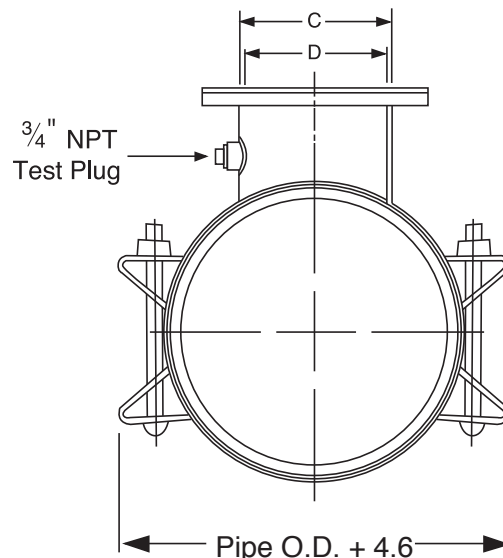
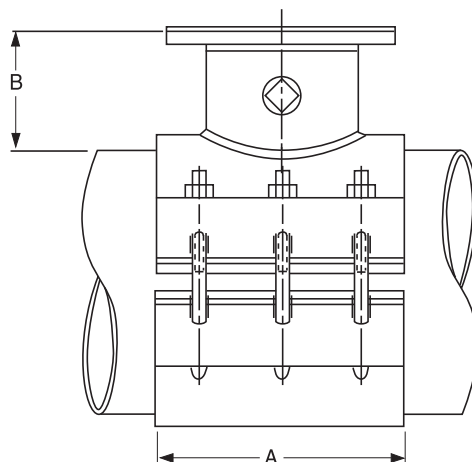

STS420 STAINLESS STEEL TAPPING SLEEVE



NOMINAL PIPE SIZE	SLEEVE O.D. RANGE (inches)	CATALOG NUMBER			LIST PRICE	APPROX. WEIGHT (lbs.)
		SLEEVE #	BY	BRANCH SIZE		
6"	6.83 - 7.16	STS420 - 7.16	X	3"	\$3,584.13	70 #
	7.05 - 7.40	STS420 - 7.40		4"	3,584.13	75 #
	7.40 - 7.73	STS420 - 7.73		6"	4,028.15	80 #
8"	7.74 - 8.35 ²	STS420 - 8.35	X	3"	3,823.56	75 #
	8.36 - 8.75 ¹	STS420 - 8.75		4"	3,823.56	80 #
	8.98 - 9.37	STS420 - 9.37		6"	4,228.42	85 #
	9.27 - 9.69	STS420 - 9.69		8"	5,223.94	90 #
10"	9.83 - 10.25 ¹	STS420 - 10.25	X	3"	4,215.35	85 #
	10.64 - 10.86	STS420 - 10.86		4"	4,215.35	90 #
	11.03 - 11.47	STS420 - 11.47		6"	4,533.13	95 #
	11.36 - 11.80	STS420 - 11.80		8"	5,577.92	100 #
	11.76 - 12.24	STS420 - 12.24		10"	7,959.13	125 #
12"	12.25 - 12.61	STS420 - 12.61	X	3"	4,271.96	100 #
	12.62 - 12.88	STS420 - 12.88		4"	4,271.96	100 #
	13.13 - 13.60	STS420 - 13.60		6"	4,733.33	105 #
	13.60 - 14.09	STS420 - 13.60		8"	5,830.40	110 #
		STS420 - 14.09		10"	8,189.85	135 #
		STS420 - 14.09	12"	10,449.19	155 #	
14"	14.10 - 14.56 ²	STS420 - 14.56	X	3"	5,303.64	105 #
	14.59 - 15.08 ²	STS420 - 15.08		4"	5,303.64	110 #
	15.23 - 15.80	STS420 - 15.80		6"	5,834.78	115 #
				8"	7,950.41	120 #
				10"	10,510.13	145 #
				12"	11,332.66	165 #
		STS420 - 15.80	14"	12,451.29	200 #	
16"	15.73 - 16.22 ¹	STS420 - 16.22	X	3"	5,669.34	115 #
	16.30 - 16.73 ¹	STS420 - 16.73		4"	5,669.34	120 #
	16.74 - 17.26	STS420 - 17.26		6"	6,230.90	125 #
	17.33 - 17.87	STS420 - 17.87		8"	8,455.39	130 #
				10"	10,780.01	160 #
				12"	11,573.61	175 #
				14"	12,886.67	215 #
		STS420 - 17.87	16"	16,564.65	270 #	
18"	17.88 - 18.43 ¹	STS420 - 18.43	X	3"	5,765.11	125 #
	18.05 - 18.61 ¹	STS420 - 18.61		4"	5,765.11	130 #
	18.62 - 19.19 ¹	STS420 - 19.19		6"	6,352.77	135 #
	18.87 - 19.45	STS420 - 19.45		8"	8,638.22	140 #
				10"	10,818.99	170 #
				12"	11,658.15	190 #
				14"	12,886.67	230 #
				16"	16,984.90	285 #
		18"	17,783.65	290 #		
20"	19.41 - 20.01 ¹	STS420 - 20.01	X	3"	5,965.36	145 #
	19.60 - 20.20 ¹	STS420 - 20.20		4"	5,965.36	150 #
	20.00 - 20.60 ¹	STS420 - 20.60		6"	6,595.90	155 #
	20.29 - 20.94 ¹	STS420 - 20.94		8"	8,960.38	160 #
	20.93 - 21.57	STS420 - 21.57		10"	10,864.64	195 #
	21.51 - 22.15	STS420 - 22.15		12"	11,660.81	210 #
	22.16 - 22.81	STS420 - 22.81		14"	13,757.38	255 #
	22.78 - 23.45	STS420 - 23.45		16"	17,394.45	315 #
	23.46 - 24.16	STS420 - 24.16		18"	18,248.22	320 #
				20"	21,347.65	390 #

¹ For size on size taps, a 1/2" undersized shell cutter is required. ² For size on size taps, 2" undersized shell cutter is required.

Other sizes, ranges and outlets available - POA.

Test plugs furnished on all applicable models.



No Cancel, No Return Item.

TO ORDER: Specify catalog number by the desired O.D. range and flange size.

EXAMPLE: STS420 - 17.87 x 6

NOTE: For flanges 14" and larger, please specify valve manufacturer upon ordering.



STS420 STAINLESS STEEL TAPPING SLEEVE

NOMINAL PIPE SIZE	SLEEVE O.D. RANGE (inches)	CATALOG NUMBER			LIST PRICE	APPROX. WEIGHT (lbs.)
		SLEEVE #	BY	BRANCH SIZE		
24"	24.15 - 24.85 24.82 - 25.52 25.71 - 26.41 26.55 - 27.25 27.26 - 27.96 27.43 - 28.13 28.14 - 28.84	STS420 - 24.85 STS420 - 25.52 STS420 - 26.41 STS420 - 27.25 STS420 - 27.96 STS420 - 28.13 STS420 - 28.84	X	3"	6,391.97	165 #
				4"	6,391.97	170 #
				6"	6,875.42	175 #
				8"	9,569.82	180 #
				10"	10,872.58	220 #
				12"	11,825.35	240 #
				14"	14,192.73	290 #
				16"	17,834.05	360 #
				18"	19,102.01	365 #
				20"	22,201.41	435 #
				24"	27,867.37	585 #
30"	29.78 - 30.48 30.48 - 31.18 31.15 - 31.85 31.30 - 32.00 31.52 - 32.22 32.20 - 33.00 33.00 - 33.80 33.80 - 34.60 34.60 - 35.40	STS420 - 30.48 STS420 - 31.18 STS420 - 31.85 STS420 - 32.00 STS420 - 32.22 STS420 - 33.00 STS420 - 33.80 STS420 - 34.60 STS420 - 35.40	X	3"	8,092.50	190 #
				4"	8,092.50	195 #
				6"	9,041.37	200 #
				8"	9,972.97	205 #
				10"	10,939.03	250 #
				12"	11,887.92	270 #
				14"	14,628.06	320 #
				16"	19,107.32	400 #
				18"	19,961.09	405 #
				20"	23,060.50	480 #
				24"	28,726.44	645 #
36"	35.40 - 36.20 36.20 - 37.00 37.00 - 37.80 37.80 - 38.60 38.60 - 39.40 39.40 - 40.20 40.20 - 41.00 41.00 - 41.80	STS420 - 36.20 STS420 - 37.00 STS420 - 37.80 STS420 - 38.60 STS420 - 39.40 STS420 - 40.20 STS420 - 41.00 STS420 - 41.80	X	3"	9,073.25	215 #
				4"	9,073.25	220 #
				6"	9,885.75	225 #
				8"	10,698.27	230 #
				10"	11,510.76	285 #
				12"	12,323.26	300 #
				14"	15,063.42	360 #
				16"	19,911.82	450 #
				18"	20,765.58	455 #
				20"	23,864.99	540 #
				24"	29,530.97	725 #
42"	41.80 - 42.60 42.60 - 43.40 43.40 - 44.20 44.20 - 45.00	STS420 - 42.60 STS420 - 43.40 STS420 - 44.20 STS420 - 45.00	X	3"	10,054.02	230 #
				4"	10,054.02	235 #
				6"	10,730.18	240 #
				8"	11,406.33	245 #
				10"	12,082.47	300 #
				12"	12,758.61	385 #
				14"	15,498.79	475 #
				16"	20,716.30	480 #
				18"	21,570.08	575 #
				20"	24,669.52	580 #
				24"	30,335.45	770 #
48"	45.00 - 45.80 45.80 - 46.60 46.60 - 47.40 47.40 - 48.20 48.20 - 49.00 49.00 - 49.80 49.80 - 50.60 50.60 - 51.40 51.40 - 52.20	STS420 - 45.80 STS420 - 46.60 STS420 - 47.40 STS420 - 48.20 STS420 - 49.00 STS420 - 49.80 STS420 - 50.60 STS420 - 51.40 STS420 - 52.20	X	3"	11,663.54	265 #
				4"	11,663.54	270 #
				6"	11,870.78	275 #
				8"	12,250.67	280 #
				10"	12,974.75	340 #
				12"	13,804.22	360 #
				14"	16,653.98	430 #
				16"	20,669.34	535 #
				18"	21,429.95	540 #
				20"	26,612.99	645 #
				24"	32,507.86	860 #

Other sizes, ranges and outlets available - POA.

Test plugs furnished on all applicable models.

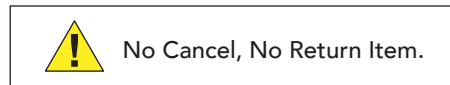

TO ORDER: Specify catalog number by the desired O.D. range and flange size.

EXAMPLE: STS420 - 42.60 x 12

NOTE: For flanges 14" and larger, please specify valve manufacturer upon ordering.