

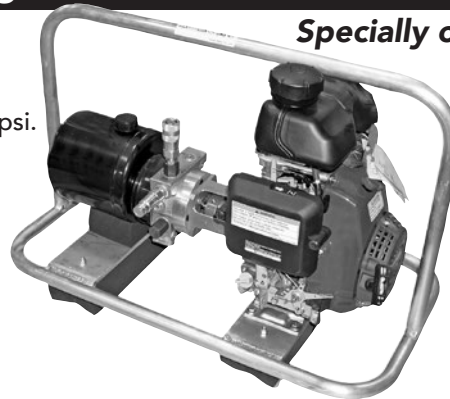

HYDRAULIC DRIVE FOR TAPMATE TOO™ PIPE DRILLING MACHINE

MATERIAL SPECIFICATIONS

- Weighs approximately 73 lbs.
- 3 h.p. Honda gasoline engine.
- Hydraulic pump delivering 2 gpm @ 1,200 psi.
- 1 gallon hydraulic fluid reservoir.
- 90 rpm hydraulic motor.
- 20 feet of connecting hoses.



Specially created for the TapMate Too

Get the most out of your TapMate Too with this self-contained power source



ITEM NUMBER	DESCRIPTION	LIST PRICE
*372-351	TapMate Too Hydraulic - Drive System, complete	\$9,226.30
*372-351-01	Base Unit	included
372-351-05	TapMate Too Hyd. Drive Head - Assembly with 1/4" Hoses	included
372-351-05	TapMate Too Hydraulic Motor and Drive Head Assembly w/ 1/4" Hoses	\$3,459.85
<small>(For adapting the Multi-Purpose Hydraulic Drive 372-01 or alternative power unit to the TapMate Too see Page TM-4)</small>		

*Considered Hazardous Material When Shipped by Air

AIR DRIVE AIR DRIVE FOR THE TAPMATE

MATERIAL SPECIFICATIONS

- Lightweight – just 11 pounds.
- Unidirectional drive clips directly to the back of the TapMate.
- Maximum .76 h.p. delivers 52 RPM.
- 191 ft-lbs. running torque, 254 ft-lbs. stall torque.

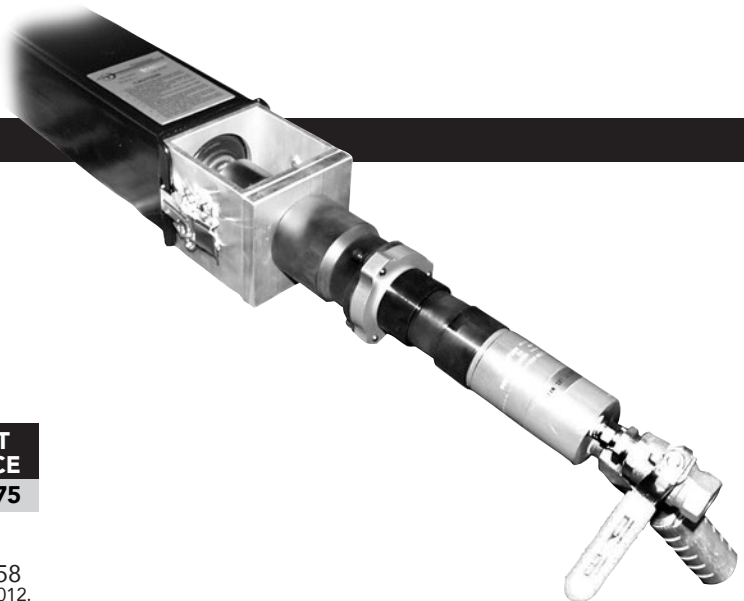

ITEM NUMBER	DESCRIPTION	LIST PRICE
371-00	Air Drive	\$11,939.75

REPLACEMENT ADAPTER LATCHES

372-06-01	Hydraulic Adapter Latch (2 req.)	ea. 24.58
<small>Includes bolts and nuts. Compatible with equipment manufactured through 2012.</small>		
372-06-99	Hydraulic Adapter Latch (2 req.)	ea. 35.28
<small>Includes bolts and nuts. Compatible with equipment manufactured after 2012.</small>		

Air drive requires connection to an air compressor capable of producing at least 36 CFM at 90 psi