

# FTS420 FABRICATED STEEL TAPPING SLEEVE



## MATERIAL SPECIFICATIONS

**BODY AND OUTLET NOZZLE:** Carbon steel, A-36 or equal. (Also available in type 304SS, Style STS420)

**BOLTS AND NUTS:** Trackhead bolts, heavy hex nuts, 3/4" UNC rolled thread, high strength, low alloy, steel per AWWA C111. Optional stainless steel, type 304.

**OUTLET GASKETS:** SBR per ASTM D2000, compounded for water and sewer service use. For 3"-12" size-on-size flanges, the gaskets are reinforced with a metal ring. Larger than 12" size-on-size sleeves use a square profile o-ring NBR per ASTM D2000 set in a full body thickness cavity. Other compounds available on request.

**TEST PLUG:** 3/4" NPT type 304 stainless steel test plug.

**FLANGE GASKETS:** 3" - 12" full face proprietary gasket are made from Styrene Butadiene Rubber (SBR) compounded for water and sewer service in accordance with ASTM D2000. Other compounds available for petroleum, chemicals or high temperature service.

**COATING:** Romacoat fusion bonded epoxy NSF 61 certified. Other coatings available. Romac packages sleeves to protect coating.

**FLANGE:** AWWA Class "D" plate flange, ANSI Class 150 drilling, proper recessing for tapping valves. Will accommodate tapping flanges per MSS SP-60. (Also Available with a threaded outlet, Style FTS420T - see page 5-11 & 5-13)

Meets requirements of MSS SP-124, and AWWA C223

**NOTE:** FTS420 is designed for rigid pipe. It is not recommended for thin or brittle pipe such as high DR C900, IPS PVC, PIP, SDR35. For these applications see SST or FTS419 product pages.

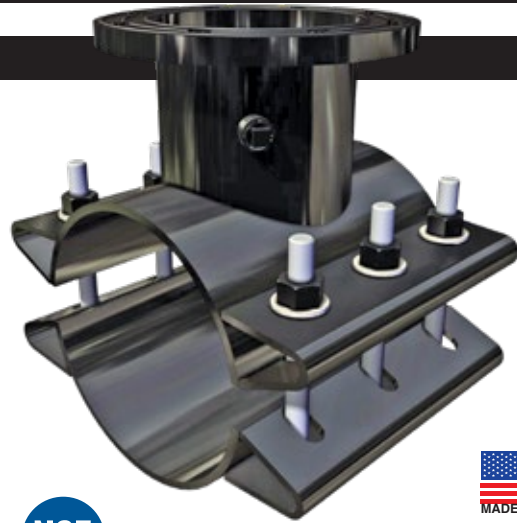
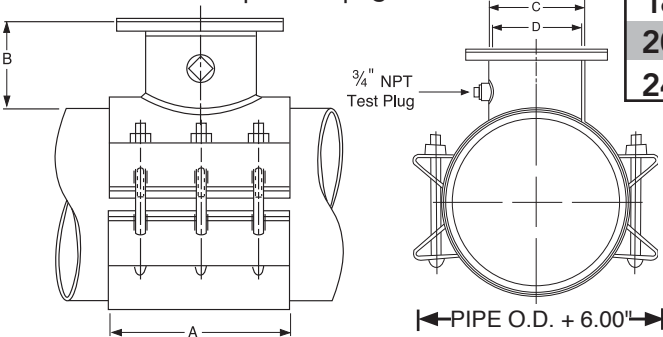

NSF61 certified upon request.

MEETS  
AWWA C223

FLANGE SIZE	A	B	C	D	BOLTS QTY: SIZE <sup>1</sup>
3"	12"	5.18"	4.03"	3 1/2"	6: 3/4" x 9"
4"	12"	5.18"	5.03"	4 1/2"	6: 3/4" x 9"
6"	12"	5.18"	7.03"	6 1/2"	6: 3/4" x 9"
8"	16"	5.18"	9.03"	8 1/2"	8: 3/4" x 9"
10"	20"	5.50"	11.03"	10 1/2"	10: 3/4" x 9"
12"	20"	5.75"	13.03"	12 1/2"	10: 3/4" x 9"
14" <sup>2</sup>	24"	6.00"	15.03"	14 1/2"	12: 3/4" x 9"
16" <sup>2</sup>	28"	6.00"	17.03"	16 1/2"	14: 3/4" x 9"
18" <sup>2</sup>	32"	6.00"	19.03"	18 1/2"	16: 3/4" x 9"
20" <sup>2</sup>	32"	6.00"	21.03"	20 1/2"	16: 3/4" x 9"
24" <sup>2</sup>	36"	6.63"	25.03"	24 1/2"	18: 3/4" x 9"

<sup>1</sup> 7.16-14.56" sizes use 8" long bolts.

<sup>2</sup> Valve Manufacturer must be specified upon ordering.

## FTS420-T FABRICATED STEEL TAPPING SADDLE

### MATERIAL SPECIFICATIONS

**THREADED OUTLET MODEL FTS420T** (for detailed information see pg. 5-11 to 5-13)

**BODY:** Carbon steel, A-36 or equal.

**OUTLET:** NPT (IP) or AWWA (CC) Female Threads

**BOLTS AND NUTS:** Trackhead bolts, heavy hex nuts, 3/4" UNC rolled thread, high strength, low alloy, steel per AWWA C111. Optional stainless steel, type 304.

**GASKETS:** SBR per ASTM D2000 MBA 710, compounded for water and sewer service use. Other compounds available on request.

**PAINT:** Romac shopcoat for corrosion protection in transit. Optional Romacoat fusion bonded epoxy NSF 61 certified. Other coatings available. Romac packages sleeves to protect any special coatings.





# FTS420 FABRICATED STEEL TAPPING SLEEVE

NOMINAL PIPE SIZE	SLEEVE O.D. RANGE (inches)	CATALOG NUMBER			LIST PRICE EACH		APPROX. WEIGHT (lbs.)
		SLEEVE #	BY	BRANCH SIZE	W/ ALLOY BOLTS	W/ 304 SS BOLTS & NUTS	
6"	6.83 - 7.16 <sup>1</sup>	FTS420 - 7.16	X	3"	\$1,221.89	\$1,428.40	65 #
	7.05 - 7.40 <sup>1</sup>	FTS420 - 7.40		4"	1,221.89	1,428.40	70 #
	7.40 - 7.73 <sup>1</sup>	FTS420 - 7.73		6"	1,434.23	1,640.72	70 #
8"	7.74 - 8.35 <sup>2</sup>	FTS420 - 8.35	X	3"	1,330.17	1,536.73	75 #
	8.36 - 8.75 <sup>1</sup>	FTS420 - 8.75		4"	1,330.17	1,536.73	75 #
	8.98 - 9.37 <sup>1</sup>	FTS420 - 9.37		6"	1,451.53	1,658.04	80 #
	9.27 - 9.69 <sup>1</sup>	FTS420 - 9.69		8"	1,824.12	2,099.45	100 #
10"	9.83 - 10.25 <sup>2</sup>	FTS420 - 10.25	X	3"	1,338.94	1,545.44	85 #
	10.64 - 10.86 <sup>1</sup>	FTS420 - 10.86		4"	1,338.94	1,545.44	85 #
	11.03 - 11.47 <sup>1</sup>	FTS420 - 11.47		6"	1,494.89	1,701.60	90 #
	11.36 - 11.80 <sup>1</sup>	FTS420 - 11.80		8"	1,893.45	2,168.75	110 #
	11.76 - 12.24	FTS420 - 12.24		10"	2,469.81	2,813.88	135 #
12"	12.25 - 12.61 <sup>2</sup>	FTS420 - 12.61	X	3"	1,447.17	1,653.69	95 #
	12.62 - 12.88 <sup>1</sup>	FTS420 - 12.88		4"	1,447.17	1,653.69	95 #
	13.13 - 13.60 <sup>1</sup>	FTS420 - 13.60		6"	1,581.52	1,788.06	100 #
	13.60 - 14.09	FTS420 - 13.60		8"	2,014.77	2,290.12	125 #
				10"	2,773.07	3,117.23	150 #
	12"	FTS420 - 14.09		12"	3,054.64	3,398.83	170 #
14"	14.10 - 14.56 <sup>2</sup>	FTS420 - 14.56	X	3"	1,516.52	1,723.01	100 #
	14.59 - 15.08 <sup>2</sup>	FTS420 - 15.08		4"	1,516.52	1,723.01	105 #
	15.23 - 15.80	FTS420 - 15.80		6"	1,767.65	1,974.19	110 #
				8"	2,034.43	2,309.79	130 #
	15.23 - 15.80	FTS420 - 15.80		10"	2,976.70	3,322.11	160 #
				12"	3,414.37	3,758.47	180 #
				14"	4,601.54	5,014.60	220 #
16"	15.73 - 16.22 <sup>1</sup>	FTS420 - 16.22	X	3"	1,577.20	1,783.73	105 #
	16.30 - 16.73 <sup>1</sup>	FTS420 - 16.73		4"	1,577.20	1,783.73	110 #
	16.74 - 17.26	FTS420 - 17.26		6"	1,767.83	1,974.31	115 #
				8"	2,034.43	2,454.79	145 #
	17.33 - 17.87	FTS420 - 17.87		10"	2,976.70	3,320.84	175 #
				12"	3,414.37	3,788.44	195 #
				14"	4,795.88	5,208.94	240 #
	16"	4,954.49		5,436.36	275 #		
18"	17.88 - 18.43 <sup>1</sup>	FTS420 - 18.43	X	3"	1,599.20	1,805.73	115 #
	18.05 - 18.61 <sup>1</sup>	FTS420 - 18.61		4"	1,599.20	1,805.73	115 #
	18.62 - 19.19 <sup>1</sup>	FTS420 - 19.19		6"	1,792.83	1,999.31	120 #
	18.87 - 19.45	FTS420 - 19.45		8"	2,109.43	2,529.79	155 #
				10"	3,096.70	3,440.84	185 #
	19.41 - 20.01	FTS420 - 20.01		12"	3,439.37	3,813.44	210 #
	19.60 - 20.20	FTS420 - 20.20		14"	5,005.39	5,418.43	250 #
				16"	5,230.08	5,711.95	300 #
	18"	5,508.89		5,990.77	330 #		
20"	20.00 - 20.60 <sup>1</sup>	FTS420 - 20.60	X	3"	1,663.78	1,870.31	130 #
	20.29 - 20.94 <sup>1</sup>	FTS420 - 20.94		4"	1,663.78	1,870.31	135 #
	20.93 - 21.57	FTS420 - 21.57		6"	1,876.17	2,082.68	140 #
				8"	2,393.97	2,669.29	175 #
	21.51 - 22.15	FTS420 - 22.15		10"	3,223.74	3,567.85	210 #
	22.16 - 22.81	FTS420 - 22.81		12"	3,518.33	3,862.48	230 #
	22.78 - 23.45	FTS420 - 23.45		14"	5,260.92	5,673.99	280 #
	23.46 - 24.16	FTS420 - 24.16		16"	5,434.49	5,916.38	325 #
				18"	5,622.36	6,104.19	360 #
	20"	6,023.45		6,505.34	375 #		

<sup>1</sup> For size on size taps, a 1/2" undersized shell cutter is required. <sup>2</sup> For size on size taps, 2" undersized shell cutter is required.

**Other sizes, ranges and outlets available - POA.**

Test plugs furnished on all applicable models.

**TO ORDER:** Specify catalog number by the desired O.D. range and flange size. Add S.S. for optional 304 stainless steel bolts & nuts.

**EXAMPLE:** FTS420 - 17.87 x 6 - SSFE

**NOTE:** For flanges 14" and larger, please specify valve manufacturer upon ordering.

# FTS420 FABRICATED STEEL TAPPING SLEEVE



NOMINAL PIPE SIZE	SLEEVE O.D. RANGE (inches)	CATALOG NUMBER			LIST PRICE EACH		APPROX. WEIGHT (lbs.)
		SLEEVE #	BY	BRANCH SIZE	W/ ALLOY BOLTS	W/ 304 SS BOLTS & NUTS	
24"	24.15 - 24.85	FTS420 - 24.85	X	3"	\$1,910.79	\$2,117.33	145 #
	24.82 - 25.52	FTS420 - 25.52		4"	1,910.79	2,117.33	150 #
	25.71 - 26.41	FTS420 - 26.41		6"	2,153.54	2,360.00	155 #
	26.55 - 27.25	FTS420 - 27.25		8"	2,790.42	3,065.78	195 #
	27.26 - 27.96	FTS420 - 27.96		10"	3,895.92	4,087.84	235 #
	27.43 - 28.13	FTS420 - 28.13		12"	4,050.53	4,339.09	260 #
	28.14 - 28.84	FTS420 - 28.84		14"	5,950.31	6,363.36	315 #
				16"	6,033.39	6,515.28	370 #
				18"	6,383.39	6,865.28	410 #
				20"	6,740.07	7,221.94	420 #
				24"	9,849.74	10,469.32	485 #
30"	29.78 - 30.48	FTS420 - 30.48	X	3"	2,088.53	2,294.99	170 #
	30.48 - 31.18	FTS420 - 31.18		4"	2,088.53	2,294.99	175 #
	31.15 - 31.85	FTS420 - 31.85		6"	2,387.39	2,593.94	180 #
	31.30 - 32.00	FTS420 - 32.00		8"	3,102.44	3,377.72	230 #
	31.52 - 32.22	FTS420 - 32.22		10"	3,851.98	4,196.13	285 #
	32.20 - 33.00	FTS420 - 33.00		12"	4,731.73	5,129.25	305 #
	33.00 - 33.80	FTS420 - 33.80		14"	6,144.05	6,557.05	370 #
	33.80 - 34.60	FTS420 - 34.60		16"	6,317.59	6,799.46	435 #
	34.60 - 35.40	FTS420 - 35.40		18"	6,667.61	7,149.48	485 #
				20"	7,103.76	7,585.59	495 #
				24"	10,383.47	11,003.04	570 #
36"	35.40 - 36.20	FTS420 - 36.20	X	3"	3,036.04	3,242.54	210 #
	36.20 - 37.00	FTS420 - 37.00		4"	3,036.04	3,242.54	215 #
	37.00 - 37.80	FTS420 - 37.80		6"	3,149.75	3,356.27	220 #
	37.80 - 38.60	FTS420 - 38.60		8"	3,697.47	3,972.82	285 #
	38.60 - 39.40	FTS420 - 39.40		10"	4,767.48	5,111.70	345 #
	39.40 - 40.20	FTS420 - 40.20		12"	5,036.28	5,380.48	370 #
	40.20 - 41.00	FTS420 - 41.00		14"	7,309.92	7,722.94	445 #
	41.00 - 41.80	FTS420 - 41.80		16"	8,718.42	9,200.29	520 #
				18"	10,200.61	10,682.47	585 #
				20"	10,523.98	11,118.60	595 #
				24"	13,403.55	14,023.10	680 #
42"	41.80 - 42.60	FTS420 - 42.60	X	3"	3,258.55	3,465.08	220 #
	42.60 - 43.40	FTS420 - 43.40		4"	3,258.55	3,465.08	225 #
	43.40 - 44.20	FTS420 - 44.20		6"	3,415.08	3,621.64	230 #
	44.20 - 45.00	FTS420 - 45.00		8"	5,120.36	5,395.72	300 #
				10"	5,620.19	5,964.40	365 #
				12"	5,880.50	6,233.16	390 #
				14"	7,848.89	8,261.91	470 #
				16"	9,250.27	9,732.14	550 #
				18"	10,732.47	11,214.34	615 #
				20"	11,168.59	11,650.45	630 #
				24"	13,935.40	14,554.96	720 #
48"	45.00 - 45.80	FTS420 - 45.80	X	3"	4,495.57	4,702.04	320 #
	45.80 - 46.60	FTS420 - 46.60		4"	4,495.57	4,702.04	325 #
	46.60 - 47.40	FTS420 - 47.40		6"	4,834.09	5,109.67	330 #
	47.40 - 48.20	FTS420 - 48.20		8"	5,332.18	5,636.17	430 #
	48.20 - 49.00	FTS420 - 49.00		10"	8,485.52	8,838.62	530 #
	49.00 - 49.80	FTS420 - 49.80		12"	8,618.42	9,127.60	560 #
	49.80 - 50.60	FTS420 - 50.60		14"	12,152.39	12,751.94	675 #
	50.60 - 51.40	FTS420 - 51.40		16"	12,922.55	13,540.81	785 #
	51.40 - 52.20	FTS420 - 52.20		18"	14,256.98	14,879.44	885 #
				20"	15,567.75	16,197.00	895 #
				24"	16,223.91	16,859.84	1,015 #