



FJ RESTRAINT FLEXIBLE EXPANSION JOINT

MATERIAL SPECIFICATIONS

USE: The FJ Restraint is a flexible ductile iron fitting, developed to accommodate pipeline forces that result in damaged pipe or loss of service. The FJ Restraint is designed to compensate for expansion, contraction, rotation, bending and settlement of your pipeline all at the same time, with one fitting.

MATERIALS

CASTINGS: The Casing, Ball and Sleeve are cast of ductile (nodular) iron, meeting or exceeding ASTM A536, Grade 65-45-12.

FLANGE ENDS: Flanges meet the dimensional requirements of ANSI Class 125 and 150 bolt circles.

MJ ENDS: Mechanical Joint ends meet the dimensional requirements of either ANSI/AWWA C111/A21.11 or ANSI/AWWA C153/A21.53 depending on size.

MJ RESTRAINT: To securely fix MJ ends of the FJ Restraint, GripRings (8-3) or RomaGrip (8-6) can be supplied.

LOCKRING: Series 400 stainless steel. Limits expansion and contraction of FlexiJoint up to maximum working pressure. Standard MJ gasket is used with this fitting. See ANSI/AWWA C111/A21.11 for specifications. Transition gaskets may be used for steel (IPS) pipe size PVC.

RING GASKETS: Ring gaskets are made of dual durometer Ethylene Propylene Diene Methylene rubber (EPDM) compounded for water and sewer service.

CASING COVERS, 3-12 INCH: Ethylene Propylene Diene Methylene (EPDM) compounded for water and sewer service.

FJ RESTRAINT™ FLEXIBLE EXPANSION JOINT

U.S. PATENT: 5,897,146

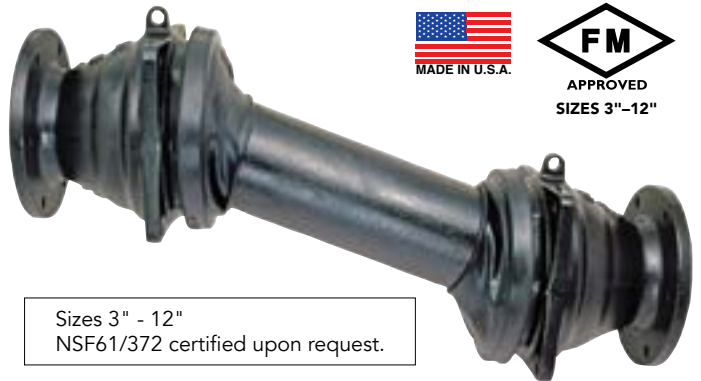

Sizes 3" - 12"
NSF61/372 certified upon request.

CASING COVERS, 14 - 24 INCH: Protective polyethylene debris cover.

COATINGS: The entire fitting is lined and coated with Romacoat fusion bonded epoxy, NSF 61 certified.

PROTECTIVE SLEEVE: Polyethylene sleeve, 8 mils thick to cover entire FJ Restraint assembly after installation. Provided with flexible rubber bands to secure to pipe ends and FJ Restraint.

PRESSURE: When properly installed the FJ Restraint can be used at working pressures up to 350 psi.

FJ RESTRAINT WITH FLANGED ENDS

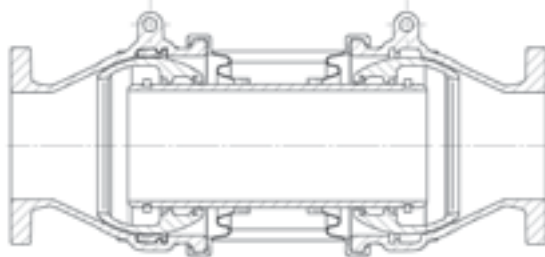

FJ RESTRAINT WITH MECHANICAL JOINT ENDS

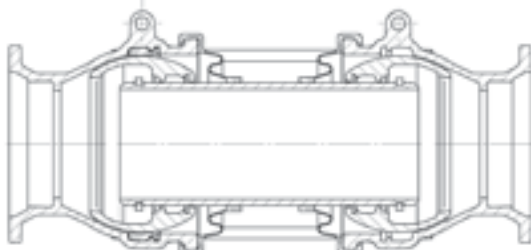

FJ RESTRAINT COMPONENTS

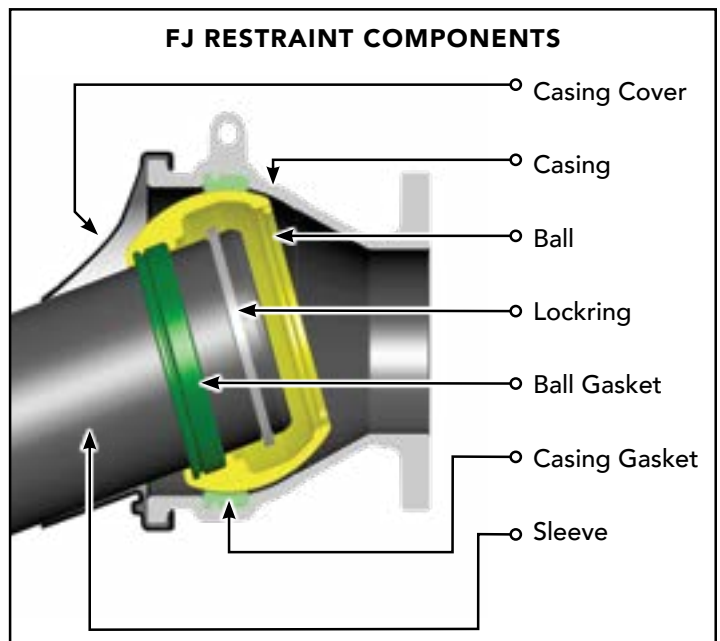

FJ RESTRAINT FLEXIBLE EXPANSION JOINT



3" - 24" DIMENSIONS

NOM SIZE	OFFSET	A	B	C	D	E	FLANGE X FLANGE	MJ X FLANGE	MJ X MJ	TOTAL EXPANSION	ANGLE	
							L1	L1	L1			L2
3"	4	6.8	6.2	8.2	5.7	11.9	24.7	24.1	23.5	4.00	20.0°	
	8						35.7	35.1	34.5			22.2
	12						46.7	46.1	45.5			33.2
	16						57.7	57.1	56.5			44.2
	20						68.7	68.1	67.5			55.2
4"	4	7.0	6.4	9.4	6.3	13.2	26.7	26.1	25.5	4.00	19.0°	
	8						37.7	37.1	36.5			23.6
	12						49.7	49.1	48.5			35.6
	16						60.7	60.1	59.5			46.6
	20						72.7	72.1	71.5			58.6
6"	4	7.9	7.5	11.9	7.4	15.6	28.9	28.6	28.2	6.26	18.0°	
	8						40.9	40.6	40.2			25.2
	12						52.9	52.6	52.2			37.2
	16						65.9	65.6	65.2			50.2
	20						77.9	77.6	77.2			62.2
8"	4	8.8	8.0	14.4	8.7	18.1	31.1	30.3	29.5	6.26	17.0°	
	8						44.1	43.3	42.5			26.4
	12						57.1	56.3	55.5			39.4
	16						70.1	69.3	68.5			52.4
	20						83.1	82.3	81.5			65.4
10"	4	9.3	8.6	16.9	10.1	20.7	33.6	32.9	32.2	6.26	16.0°	
	8						46.6	45.9	45.2			27.9
	12						60.6	59.9	59.2			41.9
	16						74.6	73.9	73.2			55.9
	20						88.6	87.9	87.2			69.9
12"	4	10.0	9.2	19.4	11.3	23.7	35.5	34.7	33.9	7.88	15.0°	
	8						50.5	49.7	48.9			30.4
	12						65.5	64.7	63.9			45.4
	16						80.5	79.7	78.9			60.4
	20						95.5	94.7	93.9			75.4
14"	4	10.9	11.0	21.7	12.7	26.2	42.9	43.0	43.1	7.88	15.0°	
	8						55.9	56.0	56.1			34.0
	12						69.9	70.0	70.1			48.0
	16						84.9	85.0	85.1			63.0
	20						99.9	100.0	100.1			78.0
16"	4	11.7	11.7	24.1	14.0	28.6	46.7	46.5	46.4	9.44	15.0°	
	8						57.7	57.5	57.4			34.0
	12						72.7	72.5	72.4			49.0
	16						87.7	87.5	87.4			64.0
	20						102.7	102.5	102.4			79.0
18"	4	12.5	12.3	26.3	15.1	30.9	49.0	48.7	48.5	9.44	15.0°	
	8						60.0	59.7	59.5			34.9
	12						74.0	73.7	73.4			48.9
	16						89.0	88.7	88.5			63.9
	20						104.0	103.7	103.5			78.9
20"	4	13.7	13.2	29.2	16.9	34.3	52.9	52.4	51.9	11.82	15.0°	
	8						61.9	61.4	60.9			34.5
	12						77.9	77.4	76.9			50.5
	16						92.9	92.4	91.9			65.5
	20						107.9	107.4	106.9			80.5
24"	4	14.9	14.5	34.7	19.7	39.4	56.2	55.8	55.4	11.82	15.0°	
	8						64.2	63.8	63.4			34.5
	12						80.2	79.8	79.4			50.5
	16						95.2	94.8	94.4			65.5
	20						110.2	109.8	109.4			80.5

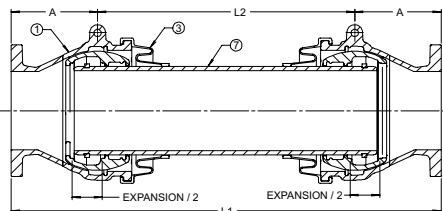
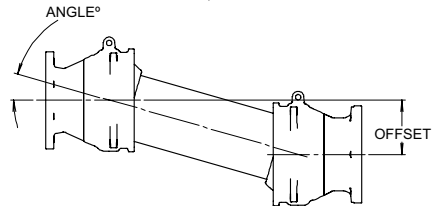
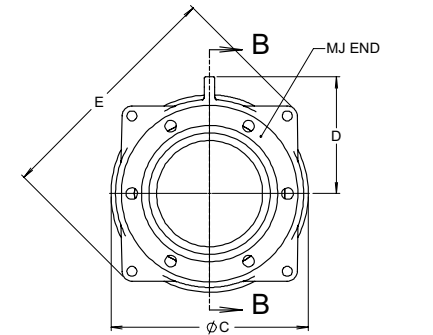
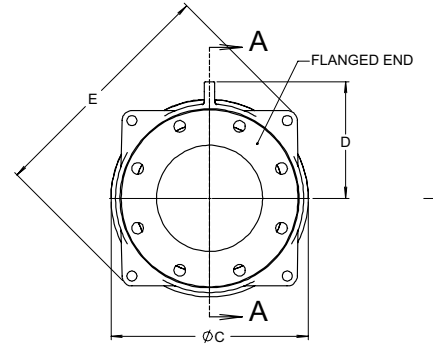

FLANGE X FLANGE

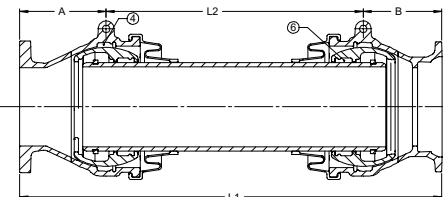

FLANGE X MJ

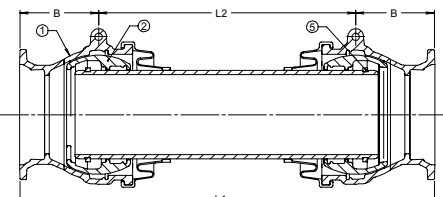

MJ X MJ

Note: Dimension L1 Equals Midpoint of Expansion.
See page 8-17 for weights.

RESTRAINT SYSTEMS



FJ RESTRAINT FLEXIBLE EXPANSION JOINT

RESTRAINT SYSTEMS

NOM. SIZE	OFFSET	FLANGE x FLANGE		FLANGE x MJ		MJ x MJ		LIST PRICE
		*LENGTH / PART NUMBER	APPROX. WT (lbs.)	*LENGTH / PART NUMBER	APPROX. WT (lbs.)	*LENGTH / PART NUMBER	APPROX. WT (lbs.)	
3"	4.0	24.67 / 221-01-0314	97	24.07 / 221-03-0314	93	23.47 / 221-02-0314	95	POA
	8.0	35.67 / 221-01-0325	110	35.07 / 221-03-0325	106	34.47 / 221-02-0325	108	
	12.0	46.67 / 221-01-0336	123	46.07 / 221-03-0336	119	45.47 / 221-02-0336	121	
	16.0	57.67 / 221-01-0347	136	57.07 / 221-03-0347	132	56.47 / 221-02-0347	134	
	20.0	68.67 / 221-01-0358	149	68.07 / 221-03-0358	145	67.47 / 221-02-0358	147	
4"	4.0	26.66 / 221-01-0416	138	26.06 / 221-03-0416	128	25.46 / 221-02-0416	133	POA
	8.0	37.66 / 221-01-0427	155	37.06 / 221-03-0427	145	36.46 / 221-02-0427	150	
	12.0	49.66 / 221-01-0439	173	49.06 / 221-03-0439	163	48.46 / 221-02-0439	168	
	16.0	60.66 / 221-01-0450	189	60.06 / 221-03-0450	179	59.46 / 221-02-0450	184	
	20.0	72.66 / 221-01-0462	207	72.06 / 221-03-0462	197	71.46 / 221-02-0462	202	
6"	4.0	28.92 / 221-01-0617	215	28.55 / 221-03-0617	200	28.18 / 221-02-0617	208	POA
	8.0	40.92 / 221-01-0629	245	40.55 / 221-03-0629	230	40.18 / 221-02-0629	237	
	12.0	52.92 / 221-01-0641	274	52.55 / 221-03-0641	260	52.18 / 221-02-0641	267	
	16.0	65.92 / 221-01-0654	307	65.55 / 221-03-0654	292	65.18 / 221-02-0654	299	
	20.0	77.92 / 221-01-0666	336	77.55 / 221-03-0666	321	77.18 / 221-02-0666	329	
8"	4.0	31.07 / 221-01-0818	331	30.27 / 221-03-0818	303	29.47 / 221-02-0818	317	POA
	8.0	44.07 / 221-01-0831	372	43.27 / 221-03-0831	344	42.47 / 221-02-0831	358	
	12.0	57.07 / 221-01-0844	414	56.27 / 221-03-0844	386	55.47 / 221-02-0844	400	
	16.0	70.07 / 221-01-0857	456	69.27 / 221-03-0857	428	68.47 / 221-02-0857	442	
	20.0	83.07 / 221-01-0870	498	82.27 / 221-03-0870	470	81.47 / 221-02-0870	484	
10"	4.0	33.61 / 221-01-1020	466	32.91 / 221-03-1020	428	32.21 / 221-02-1020	447	POA
	8.0	46.61 / 221-01-1033	520	45.91 / 221-03-1033	482	45.21 / 221-02-1033	501	
	12.0	60.61 / 221-01-1047	578	59.91 / 221-03-1047	541	59.21 / 221-02-1047	559	
	16.0	74.61 / 221-01-1061	637	73.91 / 221-03-1061	599	73.21 / 221-02-1061	618	
	20.0	88.61 / 221-01-1075	695	87.91 / 221-03-1075	657	87.21 / 221-02-1075	676	
12"	4.0	35.48 / 221-01-1221	630	34.68 / 221-03-1221	561	33.88 / 221-02-1221	596	POA
	8.0	50.48 / 221-01-1236	708	49.68 / 221-03-1236	640	48.88 / 221-02-1236	674	
	12.0	65.48 / 221-01-1251	787	64.68 / 221-03-1251	718	63.88 / 221-02-1251	752	
	16.0	80.48 / 221-01-1266	865	79.68 / 221-03-1266	796	78.88 / 221-02-1266	830	
	20.0	95.48 / 221-01-1281	943	94.68 / 221-03-1281	874	93.88 / 221-02-1281	908	
14"	4.0	42.88 / 221-01-1427	832	42.98 / 221-03-1427	776	43.08 / 221-02-1427	804	POA
	8.0	55.88 / 221-01-1440	909	55.98 / 221-03-1440	853	56.08 / 221-02-1440	881	
	12.0	69.88 / 221-01-1454	993	69.98 / 221-03-1454	937	70.08 / 221-02-1454	965	
	16.0	84.88 / 221-01-1469	1,082	84.98 / 221-03-1469	1,026	85.08 / 221-02-1469	1,054	
	20.0	99.88 / 221-01-1484	1,171	99.98 / 221-03-1484	1,115	100.08 / 221-02-1484	1,143	
16"	4.0	46.42 / 221-01-1629	1,090	46.42 / 221-03-1629	1,034	46.42 / 221-02-1629	1,062	POA
	8.0	57.42 / 221-01-1640	1,166	57.42 / 221-03-1640	1,110	57.42 / 221-02-1640	1,138	
	12.0	72.42 / 221-01-1655	1,270	72.42 / 221-03-1655	1,214	72.42 / 221-02-1655	1,242	
	16.0	87.42 / 221-01-1670	1,374	87.42 / 221-03-1670	1,318	87.42 / 221-02-1670	1,346	
	20.0	102.42 / 221-01-1685	1,477	102.42 / 221-03-1685	1,421	102.42 / 221-02-1685	1,449	
18"	4.0	48.98 / 221-01-1830	1,307	48.74 / 221-03-1830	1,259	48.50 / 221-02-1830	1,283	POA
	8.0	59.98 / 221-01-1841	1,394	59.74 / 221-03-1841	1,346	59.50 / 221-02-1841	1,370	
	12.0	73.98 / 221-01-1855	1,505	73.74 / 221-03-1855	1,457	73.50 / 221-02-1855	1,481	
	16.0	88.98 / 221-01-1870	1,625	88.74 / 221-03-1870	1,577	88.50 / 221-02-1870	1,601	
	20.0	103.98 / 221-01-1885	1,744	103.74 / 221-03-1885	1,696	103.50 / 221-02-1885	1,720	
20"	4.0	52.90 / 221-01-2032	1,755	52.40 / 221-03-2032	1,667	51.90 / 221-02-2032	1,711	POA
	8.0	61.90 / 221-01-2041	1,844	61.40 / 221-03-2041	1,756	60.90 / 221-02-2041	1,800	
	12.0	77.90 / 221-01-2057	2,004	77.40 / 221-03-2057	1,916	76.90 / 221-02-2057	1,960	
	16.0	92.90 / 221-01-2072	2,153	92.40 / 221-03-2072	2,065	91.90 / 221-02-2072	2,109	
	20.0	107.90 / 221-01-2087	2,303	107.40 / 221-03-2087	2,215	106.90 / 221-02-2087	2,259	
24"	4.0	56.22 / 221-01-2433	2,402	55.82 / 221-03-2433	2,290	55.42 / 221-02-2433	2,349	POA
	8.0	64.22 / 221-01-2441	2,503	63.82 / 221-03-2441	2,391	63.42 / 221-02-2441	2,447	
	12.0	80.22 / 221-01-2457	2,704	79.82 / 221-03-2457	2,592	79.42 / 221-02-2457	2,648	
	16.0	95.22 / 221-01-2472	2,893	94.82 / 221-03-2472	2,781	94.42 / 221-02-2472	2,837	
	20.0	110.22 / 221-01-2487	3,081	109.82 / 221-03-2487	2,969	109.42 / 221-02-2487	3,025	

* Length shown is nominal, or shipped length

Larger Sizes Available Upon Request

TO ORDER: Specify Part Number and contact Romac Quotations Department.

EXAMPLE: For a 3" Flange to Flange FJ Restraint with an offset of 4" Order: **221-01-0314**

Manufactured with Domestic and Import material. For Domestic requirements please contact our Quotations Department.

JANUARY 10, 2022 • UPDATED NOVEMBER 15, 2024