

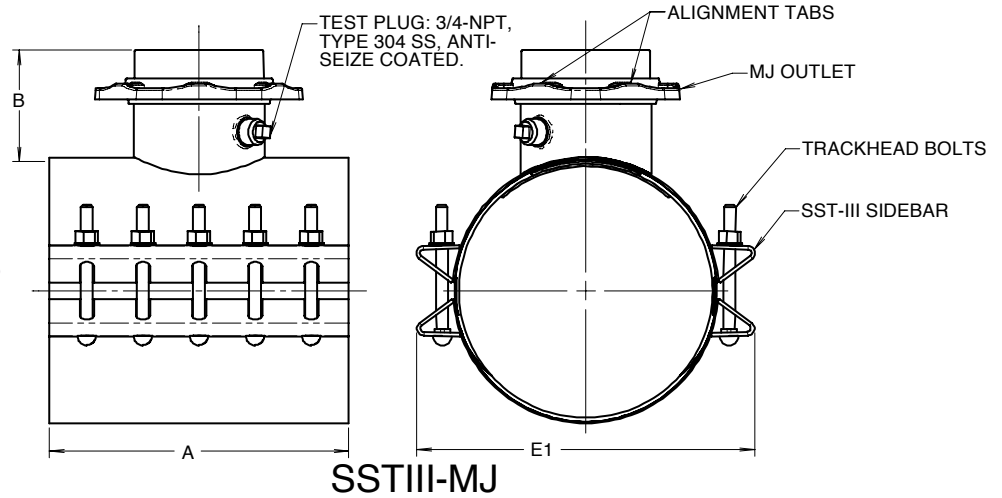

SST-MJ & SSTIII-MJ DIMENSIONS

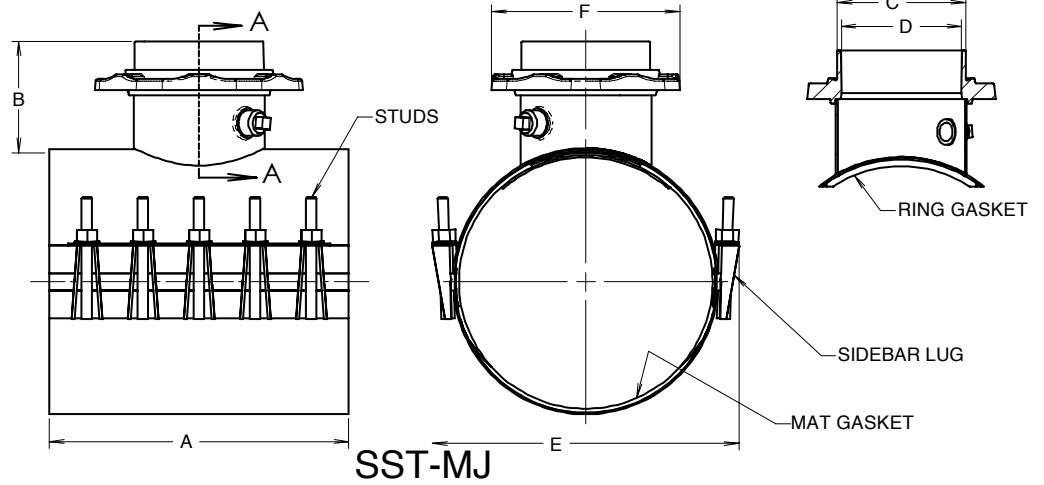

MJ SIZE	CATALOG NUMBER	# OF BOLTS	DIMENSIONS							
			A	B	C	D	E	E1	F	
4"	4.60 - 5.30	8	12.0							
	5.60 - 19.30	10	16.0	5.88	4.80	4.33	PIPE O.D. + 3.0	PIPE O.D. + 4.6	9.12	
	19.70 - 26.50	14	20.0							
	27.80 - 32.00 ¹	21	20.0							
6"	6.25 - 17.95	10	16.0							
	18.25 - 26.50	14	20.0	6.88	6.90	6.43	PIPE O.D. + 3.0	PIPE O.D. + 4.6	11.12	
	27.80 - 32.00 ¹	21	20.0							
8"	8.30 - 26.50	14	20.0	7.00	9.05	8.52	PIPE O.D. + 3.0	PIPE O.D. + 4.6	13.40	
	27.80 - 32.00 ¹	21	20.0							
10"	10.73 - 26.50	16	24.0	7.50	11.10	10.51	PIPE O.D. + 3.0	PIPE O.D. + 4.6	15.70	
	27.80 - 32.00 ¹	24	24.0							
12"	12.75 - 16.78	20	30.0							
	17.55 - 26.50	20	30.0	7.63	13.20	12.54	PIPE O.D. + 3.0	PIPE O.D. + 4.6	18.10	
	27.80 - 32.00 ¹	30	30.0							

¹ SSTIII Only

- For 3" dimensions contact Romac Engineering.
- 6.25 & 6.60 sizes not available with 6" branch.
- 8.30 size not available with 8" branch.

- 10.73 size not available with 10" branch
- 12.75 - 12.90 sizes: 1/2" undersize cutter recommended.