



**ALPHA™**  
**RESTRAINED JOINT**



**ALPHA™**  
**RESTRAINED JOINT**

**Features**  
PAGE 1-2



**Wide Range Restrained Coupling**

ORIGINALLY RELEASED IN THE SUMMER OF 2013, THE ALPHA COUPLING INSTALLS IN ABOUT THREE MINUTES, AND ACCOMMODATES UP TO 8 DEGREES OF DEFLECTION (4 DEGREES ON EACH END).

PAGE 1-4



**Wide Range Restrained End Cap**

THE ALPHA EC CAPS PLAIN-END PIPE FOR TESTING, BLOW-OFF OR LINE FLUSHING. THE ALPHA END CAP CAN ALSO BE USED AS A RELIABLE PIPE END SEAL FOR PERMANENT INSTALLATION.

PAGE 1-7



**Wide Range Restrained Flanged Coupling**

THE ALPHA FLANGED COUPLING QUICKLY ADAPTS PLAIN-END PIPE TO FLANGED FITTINGS. THE ALPHA FLANGED COUPLING ALSO ACCOMMODATES FLANGED SPOOL PIECES FOR CONNECTING TO VALVES AND OTHER FITTINGS.

PAGE 1-9



**Wide Range Restrained Tee Fitting**

ALPHA TEE RESTRAINED FITTINGS QUICKLY ADD A BRANCH CONNECTION OFF A MAIN LINE AND ARE FASTER TO INSTALL THAN A TRADITIONAL AWWA C153 MJ TEE.

PAGE 1-11

# ALPHA™

## WIDE RANGE RESTRAINED JOINT

**ROMAC**  
INDUSTRIES, INC.

# ALPHA™

## WIDE RANGE RESTRAINED JOINT

### ALPHA ADVANTAGES

- Standard Alpha covers IPS PVC through Ductile Iron pipe diameters.
- Alpha XL accommodates Ductile Iron through Oversize Cast Iron pipe sizes.
- Alpha can be configured to transition from IPS PVC up to Oversize Cast Iron pipe diameters.
- One piece, stab-fit installation.
- Cast components are high strength ductile iron.
- Working pressure: up to 350 PSI.
- Manufactured in the U.S.A.
- US Patent: 8,894,100 & 9,534,714
- Alpha products are approved for use on:
  - Ductile iron
  - Cast iron (Classes A, B, C & D)
  - PVC IPS size (Sch 40, Sch 80 & SDR 21)
  - PVC C900 and C909
  - HDPE size 4"-12": SDR 9, 11, 13.5 & 17, no pipe stiffeners required.





For other pipe materials, contact Romac.

**NOTE:** The 16" Alpha XL is not compatible with HDPE and the original Alpha (with black grippers) is not compatible with HDPE pipe.

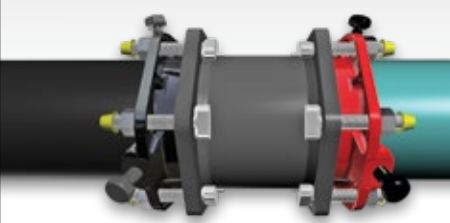
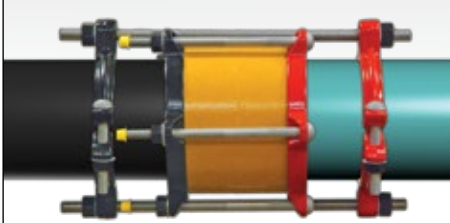

Certified to  
NSF/ANSI 61 & 372

### INSTALLATION TIME IS A FRACTION OF OTHER RESTRAINT METHODS

6" SLEEVE AND TWO MJ RESTRAINERS	6" COUPLING PLUS RESTRAINT SYSTEM	ALPHA
		
		
<b>30</b> MINUTES TO INSTALL <b>29</b> TOTAL PARTS TO ASSEMBLE <b>12</b> T-BOLTS TO TORQUE <b>9</b> RADIAL BOLTS TO TORQUE <b>2</b> GASKETS TO SEAT	<b>35</b> MINUTES TO INSTALL <b>33</b> TOTAL PARTS TO ASSEMBLE <b>5</b> COUPLING BOLTS TO TORQUE <b>4</b> CLAMPING BOLTS TO TORQUE <b>2</b> GASKETS TO SEAT	<b>3</b> MINUTES TO INSTALL <b>2</b> NUTS TO TORQUE <b>1</b> PIECE (STAB-FIT) <b>0</b> GUESS-WORK





# ALPHA™ WIDE RANGE RESTRAINED JOINT

## KEY ALPHA COMPONENTS

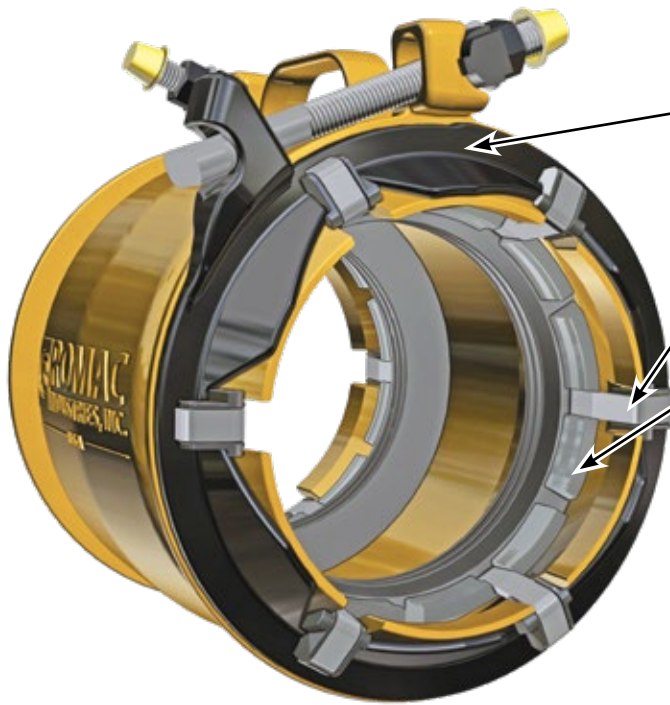

**ROTATING END RINGS**

- During installation, the end rings rotate and slide the draw hooks, gasket and grippers outward, against the pipe surface.

**DRAW HOOK FASTENERS**

- Stainless steel draw hooks are integrated into the gasket.

**INDIVIDUAL GRIPPERS**

- Individual ductile iron grippers compensate for angular deflection and out-of-round pipe.
- The grippers distribute the load evenly around the pipe circumference.

## HOW ALPHA WORKS

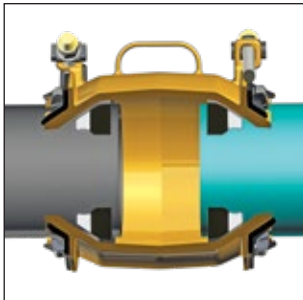

1 • Alpha is positioned over the pipe gap.

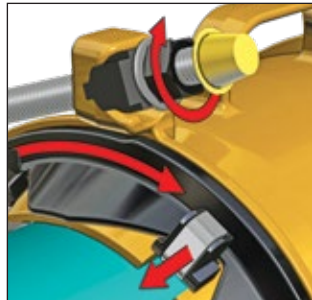

2 • Nuts are tightened, rotating the end ring.

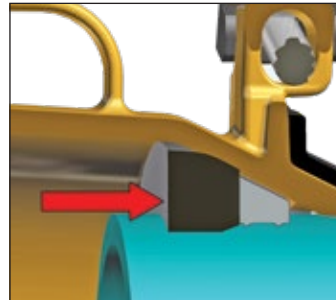

3 • Draw hooks pull gasket and grippers outward against the pipe.

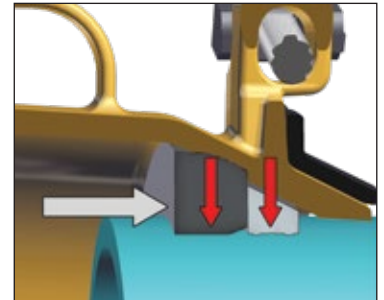

4 • Gaskets compress and seal against the pipe surface. Gripper teeth are set.

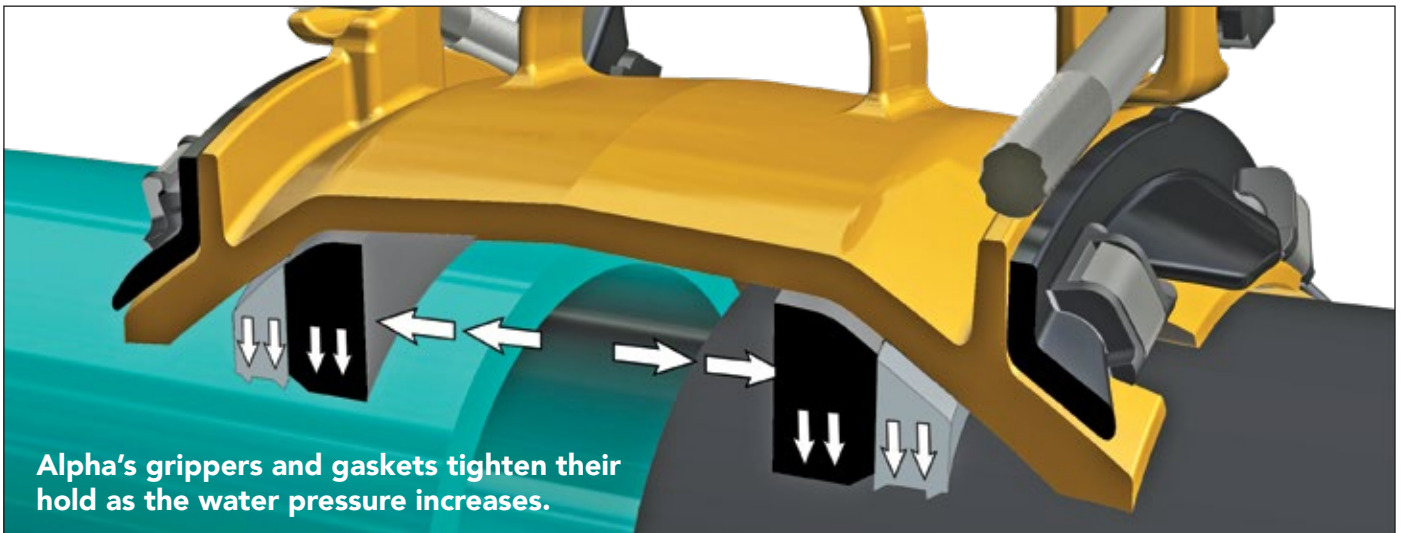

Alpha's grippers and gaskets tighten their hold as the water pressure increases.

# ALPHA™ WIDE RANGE RESTRAINT COUPLING



## MATERIAL SPECIFICATIONS

**CASTINGS:** All cast components (end rings, center ring and bolt guides) are ductile iron, meeting or exceeding the requirements of ASTM A536, grade 65-45-12.

**GRIPPERS:** Ductile (nodular) iron, meeting or exceeding ASTM A536, grade 65-45-12. Machine sharpened and heat treated. Xylan 1424 coated for corrosion protection.

**GASKET:** SBR compounded for water and sewer service in accordance with ASTM D2000. NBR available upon request. NSF/ANSI 61 & 372 Certified.

**DRAW-HOOK FASTENERS:** 304L stainless steel.

**RAMP RUNNERS:** Reinforced nylon.

**BOLTS & NUTS:** 304 stainless steel, 5/8-11 bolts with heavy hex e-coated nuts. Fasteners provided with anti-galling protection.

**COATINGS:** Center ring Romacoat fusion bonded epoxy, NSF 61 certified. End rings are Romabond polyester.

**WORKING PRESSURE:** Up to 350 PSI.



STANDARD ALPHA  
FITS IPS PVC THROUGH  
DUCTILE IRON PIPE OD'S.



Certified to  
NSF/ANSI 61 & 372



# ALPHA™

RESTRAINED JOINT

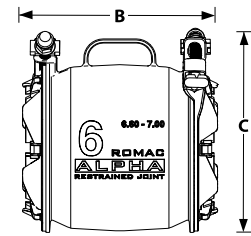
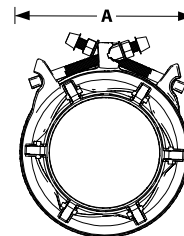

NOM. PIPE SIZE	O.D. RANGE (inches)	CATALOG NUMBER	DIMENSIONS			LIST PRICE	AP- PROX. WEIGHT (lbs)
			A O.D.	B LENGTH	C HEIGHT		
4"	4.50 - 4.90	ALPHA-A - 4.90	8.10	11.80	9.80	\$676.97	40
6"	6.60 - 7.00	ALPHA-A - 7.00	10.40	12.00	12.00	932.40	50
8"	8.60 - 9.10	ALPHA-A - 9.10	13.50	13.20	15.10	1,204.26	75
10"	10.75 - 11.20	ALPHA-A - 11.20	15.60	13.20	17.20	1,528.65	95
12"	12.75 - 13.30	ALPHA-A - 13.30	17.60	13.30	19.20	1,799.72	100

**TO ORDER:** Determine the O.D. of the pipes to be coupled, and select coupling size which covers the pipe diameters of both pipe ends. Specify Alpha Catalog Number [in table above]. Example: To couple 8" DI and 8" IPS PVC Pipe order **ALPHA-A-9.10**



# ALPHA™ XL WIDE RANGE RESTRAINT COUPLING

## MATERIAL SPECIFICATIONS

**CASTINGS:** All cast components (end rings, center ring and bolt guides) are ductile iron, meeting or exceeding the requirements of ASTM A536, grade 65-45-12.

**GRIPPERS:** Ductile (nodular) iron, meeting or exceeding ASTM A536, grade 65-45-12. Machine sharpened and heat treated. Xylan 1424 coating for corrosion protection.

**GASKETS:** 4"-12" NBR; 16" SBR. Gaskets compounded for water and sewer service in accordance with ASTM D2000. NSF/ANSI 61 & 372 Certified.

**DRAW-HOOK FASTENERS:** 304L stainless steel.

**RAMP RUNNERS:** Reinforced nylon.

**BOLTS & NUTS:** 304 stainless steel, 5/8-11 bolts with heavy hex e-coated nuts. Fasteners provided with anti-galling protection.

**COATINGS:** Center ring Romacoat fusion bonded epoxy, NSF 61 certified. End rings are Romabond polyester.

**WORKING PRESSURE:** Up to 350 PSI.



**ALPHA XL  
FITS DUCTILE IRON THROUGH  
OVERSIZE CAST IRON PIPE OD'S.**



Certified to  
NSF/ANSI 61 & 372



## ALPHA XL™ RESTRAINED JOINT

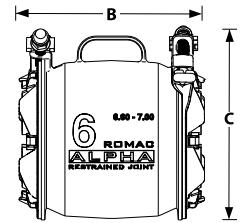
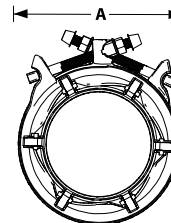

NOM. PIPE SIZE	O.D. RANGE (inches)	CATALOG NUMBER	DIMENSIONS			LIST PRICE	AP-PROX. WEIGHT (lbs)
			A O.D.	B LENGTH	C HEIGHT		
4"	4.80 - 5.10	ALPHA XL - 5.10	8.10	11.80	9.80	\$704.06	40
6"	6.90 - 7.10	ALPHA XL- 7.10	10.40	12.00	12.00	969.70	50
8"	9.05 - 9.40	ALPHA XL - 9.40	13.50	13.20	15.10	1,252.43	75
10"	11.10 - 11.45	ALPHA XL - 11.45	15.60	13.20	17.20	1,589.79	95
12"	13.20 - 13.60	ALPHA XL - 13.60	17.60	13.30	19.20	1,871.71	100
*16"	17.40 - 17.85	ALPHA XL - 17.85	23.60	15.30	25.50	5,543.95	230

\* 16" is not compatible with HDPE pipe

**TO ORDER:** Determine the O.D. of the pipes to be coupled, and select coupling size which covers the pipe diameters of both pipe ends. Example: To couple 8" Oversize Cast Iron Pipe and 8" C900 PVC pipe, order **ALPHA-XL- 9.40**.



# ALPHA™ TC

## WIDE RANGE TRANSITION RESTRAINED COUPLING



### MATERIAL SPECIFICATIONS

**CASTINGS:** All cast components (end rings, center ring and bolt guides) are ductile iron, meeting or exceeding the requirements of ASTM A536, grade 65-45-12.

**GRIPPERS:** Ductile (nodular) iron, meeting or exceeding ASTM A536, grade 65-45-12. Machine sharpened and heat treated. Xylan 1424 coating for corrosion protection.

**GASKETS:** 4"-12" NBR. Gaskets compounded for water and sewer service in accordance with ASTM D2000. NSF/ANSI 61 & 372 Certified.

**DRAW-HOOK FASTENERS:** 304L stainless steel.

**RAMP RUNNERS:** Reinforced nylon.

**BOLTS & NUTS:** 304 stainless steel, 5/8-11 bolts with heavy hex e-coated nuts. Fasteners provided with anti-galling protection. 316 stainless steel available by request.

**COATINGS:** Center ring Romacoat fusion bonded epoxy, NSF 61 certified. End rings are Romabond polyester.

**WORKING PRESSURE:** Up to 350 PSI.



Certified to  
NSF/ANSI 61 & 372

**ALPHA TC**  
FITS IPS THROUGH OVERSIZE  
CAST IRON PIPE OD'S.



# ALPHA TC™

## RESTRAINED JOINT

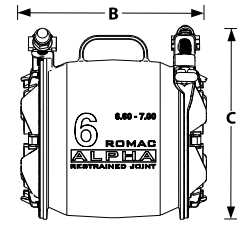
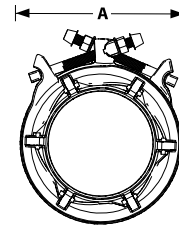

NOM. PIPE SIZE	O.D. RANGE (inches)	CATALOG NUMBER	DIMENSIONS			LIST PRICE	AP- PROX. WEIGHT (lbs)
			A O.D.	B LENGTH	C HEIGHT		
4"	4.80-5.10 x 4.50-4.90	ALPHA TC - 5.10 x 4.90	8.10	11.80	9.80	\$697.30	40
6"	6.90-7.10 x 6.60-7.00	ALPHA TC- 7.10 x 7.00	10.40	12.00	12.00	960.37	50
8"	9.05-9.40 x 8.60-9.10	ALPHA TC - 9.40 x 9.10	13.50	13.20	15.10	1,240.39	75
10"	11.10-11.45 x 10.75-11.20	ALPHA TC - 11.45 x 11.20	15.60	13.20	17.20	1,574.51	95
12"	13.20-13.60 x 12.75-13.30	ALPHA TC - 13.60 x 13.30	17.60	13.30	19.20	1,853.71	100

**TO ORDER:** Determine the O.D. of the pipes to be coupled, and select coupling size which covers the pipe diameters of both pipe ends. Example: To couple 8" Oversize Cast Iron Pipe and 8" C900 PVC pipe, order **ALPHA TC - 9.40 x 9.10**.



# ALPHA™ END CAP RESTRAINED END CAP

## MATERIAL SPECIFICATIONS

**CASTINGS:** All cast components (end rings, center ring and bolt guides) are ductile iron, meeting or exceeding the requirements of ASTM A536, grade 65-45-12.

**GRIPPERS:** Ductile (nodular) iron, meeting or exceeding ASTM A536, grade 65-45-12. Machine sharpened and heat treated. Xylan 1424 coated for corrosion protection.

**GASKET:** SBR compounded for water and sewer service in accordance with ASTM D2000. NBR available upon request. NSF/ANSI 61 & 372 Certified.

**DRAW-HOOK FASTENERS:** 304L stainless steel.

**RAMP RUNNERS:** Reinforced nylon.

**BOLT & NUT:** R-Blue. HSLA. Xylan coated to reduce friction and provide corrosion resistance. For details, see catalog page 10-3.

**WASHER:** 304 Stainless steel.

**COATINGS:** End cap Romacoat fusion bonded epoxy, NSF 61 certified. End rings are Romabond polyester.

**WORKING PRESSURE:** Up to 350 PSI.



Certified to NSF/ANSI 61 & 372

**STANDARD ALPHA END CAP**  
FITS IPS PVC THROUGH  
DUCTILE IRON PIPE OD'S.

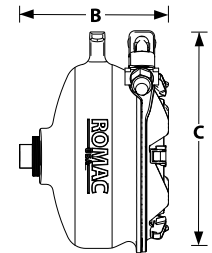
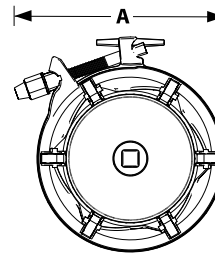

NOM. PIPE SIZE	O.D. RANGE (inches)	CATALOG NUMBER	DIMENSIONS			LIST PRICE	AP-PROX. WEIGHT (lbs)
			A O.D.	B LENGTH	C HEIGHT		
4"	4.50 - 4.90	ALPHA-EC - 4.90	8.10	7.40	9.80	\$480.45	21
6"	6.60 - 7.00	ALPHA-EC - 7.00	10.40	7.90	12.00	616.50	30
8"	8.60 - 9.10	ALPHA-EC - 9.10	13.40	9.70	15.10	862.17	52
10"	10.75 - 11.20	ALPHA-EC - 11.20	15.50	9.90	17.10	1,347.77	63
12"	12.75 - 13.30	ALPHA-EC - 13.30	17.50	10.30	19.20	1,507.19	78

**TO ORDER:** Determine the O.D. of the pipe to be capped, and select end cap size which covers the pipe diameter. Specify Catalog Number. **EXAMPLE:** To cap an 8" DI or 8" IPS PVC pipe, order **ALPHA-EC - 9.10**

### MATERIAL SPECIFICATIONS

**CASTINGS:** All cast components (end rings, center ring and bolt guides) are ductile iron, meeting or exceeding the requirements of ASTM A536, grade 65-45-12.

**GRIPPERS:** Ductile (nodular) iron, meeting or exceeding ASTM A536, grade 65-45-12. Machine sharpened and heat treated. Xylan 1424 coated for corrosion protection.

**GASKETS:** 4"-12" NBR; 16" SBR. Gaskets compounded for water and sewer service in accordance with ASTM D2000. NSF/ANSI 61 & 372 Certified.

**DRAW-HOOK FASTENERS:** 304L stainless steel.

**RAMP RUNNERS:** Reinforced nylon.

**BOLT & NUT:** R-Blue. HSLA. Xylan coated to reduce friction and provide corrosion resistance. For details, see catalog page 10-3.

**WASHER:** 304 Stainless steel.

**COATINGS:** End cap Romacoat fusion bonded epoxy, NSF 61 certified. End rings are Romabond polyester.

**WORKING PRESSURE:** Up to 350 PSI.

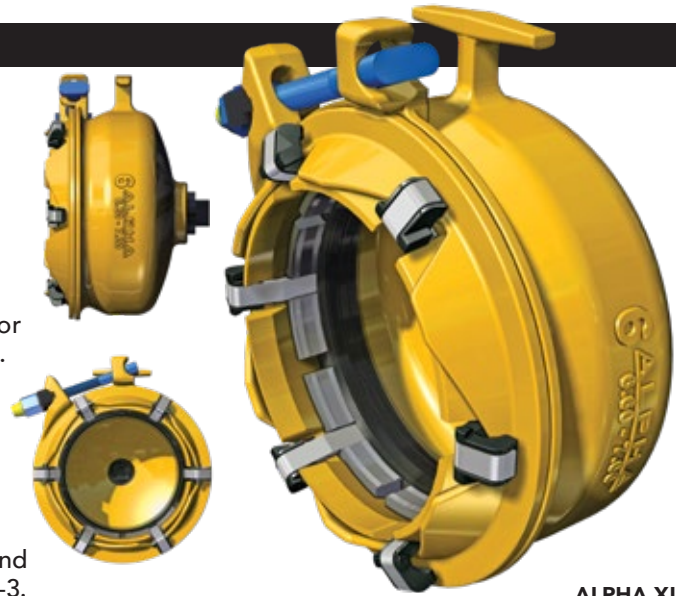

**ALPHA XL**  
FITS DUCTILE IRON THROUGH  
OVERSIZE CAST IRON PIPE OD'S.



Certified to  
NSF/ANSI 61 & 372

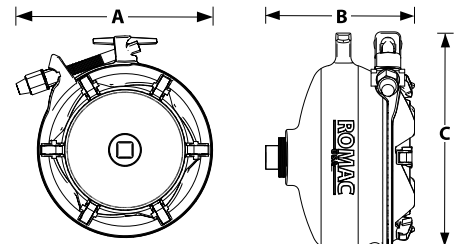

# ALPHA XL™

## RESTRAINED END CAP

NOM. PIPE SIZE	O.D. RANGE (inches)	CATALOG NUMBER	DIMENSIONS			LIST PRICE	AP-PROX. WEIGHT (lbs)
			A O.D.	B LENGTH	C HEIGHT		
4"	4.80 - 5.10	ALPHA EC XL - 5.10	8.10	7.40	9.80	\$490.04	21
6"	6.90 - 7.10	ALPHA EC XL - 7.10	10.40	7.90	12.00	628.84	30
8"	9.05 - 9.40	ALPHA EC XL - 9.40	13.40	9.70	15.10	879.42	52
10"	11.10 - 11.45	ALPHA EC XL - 11.45	15.50	9.90	17.10	1,374.72	63
12"	13.20 - 13.60	ALPHA EC XL - 13.60	17.50	10.30	19.20	1,537.33	78
*16"	17.40 - 17.85	ALPHA EC XL - 17.85	23.70	12.00	25.60	4,642.84	180

\* 16" is not compatible with HDPE pipe

**TO ORDER:** Determine the O.D. of the pipe to be capped, and select end cap size which covers the pipe diameter. Specify Catalog Number. **EXAMPLE:** To cap an 8" DI or 8" Cast Iron pipe, order **ALPHA-EC-XL -9.40**





# ALPHA™ FC RESTRAINED FLANGED COUPLING

## MATERIAL SPECIFICATIONS

**CASTINGS:** All cast components (end rings, center ring and bolt guides) are ductile iron, meeting or exceeding the requirements of ASTM A536, grade 65-45-12.

**FLANGE:** Compatible with flat face flanges with ANSI Class 125 and 150 bolt circles. See page 10-6 for filler flange.

**GRIPPERS:** Ductile (nodular) iron, meeting or exceeding ASTM A536, grade 65-45-12. Machine sharpened and heat treated. Xylan 1424 coated for corrosion protection.

**GASKET:** SBR compounded for water and sewer service in accordance with ASTM D2000. NBR available upon request. NSF/ANSI 61 & 372 Certified.

**DRAW-HOOK FASTENERS:** 304L stainless steel.

**RAMP RUNNERS:** Reinforced nylon.

**BOLT & NUT:** 304 stainless steel, 5/8-11 bolts with heavy hex e-coated nuts. Fasteners provided with anti-galling protection.

**WASHER:** 304 Stainless steel.

**COATINGS:** Flanged coupling Romacoat fusion bonded epoxy, NSF 61 certified. End rings are Romabond polyester.

**WORKING PRESSURE:** Up to 350 PSI.



**STANDARD ALPHA FC**  
FITS IPS PVC THROUGH  
DUCTILE IRON PIPE OD'S.



Certified to  
NSF/ANSI 61 & 372



# ALPHA™ FC

## RESTRAINED FLANGED COUPLING

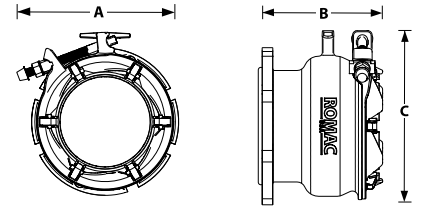

NOM. PIPE SIZE	O.D. RANGE (inches)	CATALOG NUMBER	DIMENSIONS			LIST PRICE	AP-PROX. WEIGHT (lbs)
			A O.D.	B LENGTH	C HEIGHT		
4"	4.50 - 4.90	ALPHA-FC - 4.90	11.20	8.15	10.25	\$685.10	29
6"	6.60 - 7.00	ALPHA-FC - 7.00	11.35	8.24	12.45	704.53	40
8"	8.60 - 9.10	ALPHA-FC - 9.10	13.40	9.96	15.55	885.56	57
10"	10.75 - 11.20	ALPHA-FC - 11.20	15.45	10.18	17.65	1,406.43	82
12"	12.75 - 13.30	ALPHA-FC - 13.30	17.50	10.28	19.70	1,575.69	105

**TO ORDER:** Determine the O.D. of the pipes to be coupled. Specify Catalog Number.

**EXAMPLE:** To couple an 8" DI or 8" IPS PVC pipe, order **ALPHA-FC -9.10**

### MATERIAL SPECIFICATIONS

**CASTINGS:** All cast components (end rings, center ring and bolt guides) are ductile iron, meeting or exceeding the requirements of ASTM A536, grade 65-45-12.

**FLANGE:** Compatible with flat face flanges with ANSI Class 125 and 150 bolt circles. See page 10-6 for filler flange.

**GRIPPERS:** Ductile (nodular) iron, meeting or exceeding ASTM A536, grade 65-45-12. Machine sharpened and heat treated. Xylan 1424 coated for corrosion protection.

**GASKETS:** NBR compounded for water and sewer service in accordance with ASTM D2000. NSF/ANSI 61 & 372 Certified.

**DRAW-HOOK FASTENERS:** 304L stainless steel.

**RAMP RUNNERS:** Reinforced nylon.

**BOLT & NUT:** 304 stainless steel, 5/8-11 bolts with heavy hex e-coated nuts. Fasteners provided with anti-galling protection.

**WASHER:** 304 Stainless steel.

**COATINGS:** Flanged coupling body Romacoat fusion bonded epoxy, NSF 61 certified. End rings are Romabond polyester.

**WORKING PRESSURE:** Up to 350 PSI.



ALPHA XL FC  
FITS DUCTILE IRON THROUGH  
OVERSIZE CAST IRON PIPE OD'S.



Certified to  
NSF/ANSI 61 & 372



# ALPHA™ FC

## RESTRAINED FLANGED COUPLING

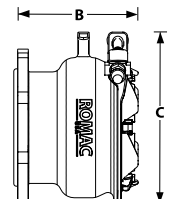
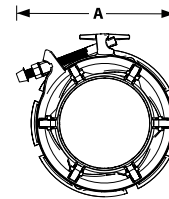

NOM. PIPE SIZE	O.D. RANGE (inches)	CATALOG NUMBER	DIMENSIONS			LIST PRICE	AP-PROX. WEIGHT (lbs)
			A O.D.	B LENGTH	C HEIGHT		
4"	4.80 - 5.10	ALPHA FC XL - 5.10	11.20	8.15	10.25	\$698.78	29
6"	6.90 - 7.10	ALPHA FC XL- 7.10	11.35	8.24	12.45	718.61	40
8"	9.05 - 9.40	ALPHA FC XL - 9.40	13.40	9.96	15.55	903.28	57
10"	11.10 - 11.45	ALPHA FC XL - 11.45	15.45	10.18	17.65	1,434.55	82
12"	13.20 - 13.60	ALPHA FC XL - 13.60	17.50	10.28	19.70	1,607.19	105

**TO ORDER:** Determine the O.D. of the pipes to be coupled. Specify Alpha Catalog Number.

**EXAMPLE:** To couple an 8" DI or 8" cast iron pipe, order **ALPHA-FC-XL-9.40**

# ALPHA™ TEE RESTRAINED FITTING



## MATERIAL SPECIFICATIONS

**CASTINGS:** All cast components (end rings, center ring, and bolt guides) are ductile iron, meeting or exceeding the requirements of ASTM A536, grade 65-45-12.

**GRIPPERS:** Ductile (nodular) iron, meeting or exceeding ASTM A536, Grade 65-45-12. Machine sharpened and heat treated. Xylan 1424 coated for superior corrosion resistance.

**GASKETS:** SBR compounded for water and sewer service per ASTM D2000, classified by UL to meet NSF61 or NBR compounded for water and sewer service per ASTM D2000, NSF61 Certified.

**DRAW HOOKS:** Uncoated 304 stainless steel.

**RAMP RUNNERS:** Reinforced nylon.

**BOLTS AND NUTS:** R-Blue. 5/8-11 bolts with heavy hex nuts. Xylan coated to reduce friction and provide corrosion resistance. Washer is 304 stainless steel.

**COATINGS:** Center ring is Romacoat fusion bonded epoxy, NSF 61 certified. End rings are Romabond polyester.



# ALPHA™ TEE

RESTRAINED FITTING

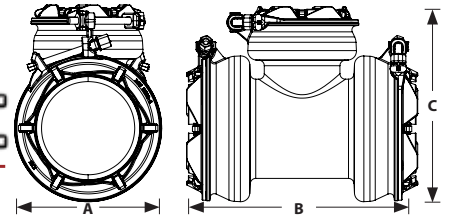

NOM. PIPE SIZE	O.D. RANGE (inches)	O.D. RANGE BRANCH (inches)	CATALOG NUMBER	DIMENSIONS			LIST PRICE	AP-PROX. WEIGHT (lbs)
				A O.D.	B LENGTH	C HEIGHT		
6x6x6	6.60 - 7.00	6.60 - 7.00	ALPHA-TEE - 7.00 x 7.00	10.33	19.28	14.59	\$1,275.56	90
8x8x6	8.60 - 9.10	6.60 - 7.00	ALPHA-TEE - 9.10 x 7.00	13.29	21.09	17.78	1,560.59	135
10x10x6	10.75 - 11.20	6.60 - 7.00	ALPHA-TEE - 11.20 x 7.00	15.40	21.71	19.84	2,158.86	155
12x12x6	12.75 - 13.30	6.60 - 7.00	ALPHA-TEE - 13.30 x 7.00	17.52	23.52	21.15	2,726.09	180

**TO ORDER:** Determine the O.D. of the pipes to be coupled. Specify Catalog Number.

**EXAMPLE:** For a tee with an 8" DI or 8" IPS PVC run and a 6" DI or IPS PVC branch, order **ALPHA-TEE - 9.10 x 7.00**